

* AT FULL DIFFERENTIAL PRESSURE FOR CLEAN FLUIDS WITH PTFE SEATS

SIZE	A	øD	øD1	E	F	G1	G2	J1	øK1	øK2	øL1	øL2	ISO 5211	WEIGHT (lbs)	Cv	TORQUE* (in-lbf)	BODY BOLT SIZE	BODY NUT SIZE
1/2"	0.35 (9)	0.37 (9)	0.98 (25)	3.50 (89)	4.92 (125)	2.91 (74)	1.65 (42)	0.35 (9)	0.24 (6)	0.24 (6)	1.42 (36)	1.65 (42)	F03-F04	1.2	7	50	5/16" x 48	5/16"
3/4"	0.35 (9)	0.62 (16)	0.98 (25)	4.13 (105)	4.92 (125)	2.91 (74)	1.77 (45)	0.35 (9)	0.24 (6)	0.24 (6)	1.42 (36)	1.65 (42)	F03-F04	1.3	26	50	5/16" x 48	5/16"
1"	0.43 (11)	0.87 (22)	2.01 (51)	4.49 (114)	6.10 (155)	3.50 (89)	2.20 (56)	0.43 (11)	0.24 (6)	0.28 (7)	1.65 (42)	1.97 (50)	F04-F05	3	61	93	5/16" x 63	5/16"
1-1/2"	0.55 (14)	1.37 (35)	2.01 (51)	5.51 (140)	7.28 (185)	4.33 (110)	3.00 (76)	0.55 (14)	0.28 (7)	0.35 (9)	1.97 (50)	2.76 (70)	F05-F07	4	182	161	3/8" x 88	3/8"
2"	0.55 (14)	1.87 (47)	2.52 (64)	6.14 (156)	7.28 (185)	4.64 (118)	3.27 (83)	0.55 (14)	0.28 (7)	0.35 (9)	1.97 (50)	2.76 (70)	F05-F07	7	410	223	3/8" x 102	3/8"
2-1/2"	0.67 (17)	2.37 (60)	3.07 (78)	7.76 (197)	9.76 (248)	6.42 (163)	4.25 (108)	0.67 (17)	0.35 (9)	0.43 (11)	2.76 (70)	4.02 (102)	F07-F10	17	710	415	1/2" x 145	1/2"
3"	0.67 (17)	2.87 (73)	3.58 (91)	9.01 (229)	9.76 (248)	6.77 (172)	4.60 (117)	0.67 (17)	0.35 (9)	0.43 (11)	2.76 (70)	4.02 (102)	F07-F10	26	1100	589	1/2" x 165	1/2"
4"	0.87 (22)	3.82 (97)	4.68 (119)	9.49 (241)	15.55 (395)	7.95 (202)	5.51 (140)	0.87 (22)	0.43 (11)	0.51 (13)	4.01 (102)	4.92 (125)	F10-F12	44	2050	774	5/8" x 194	5/8"

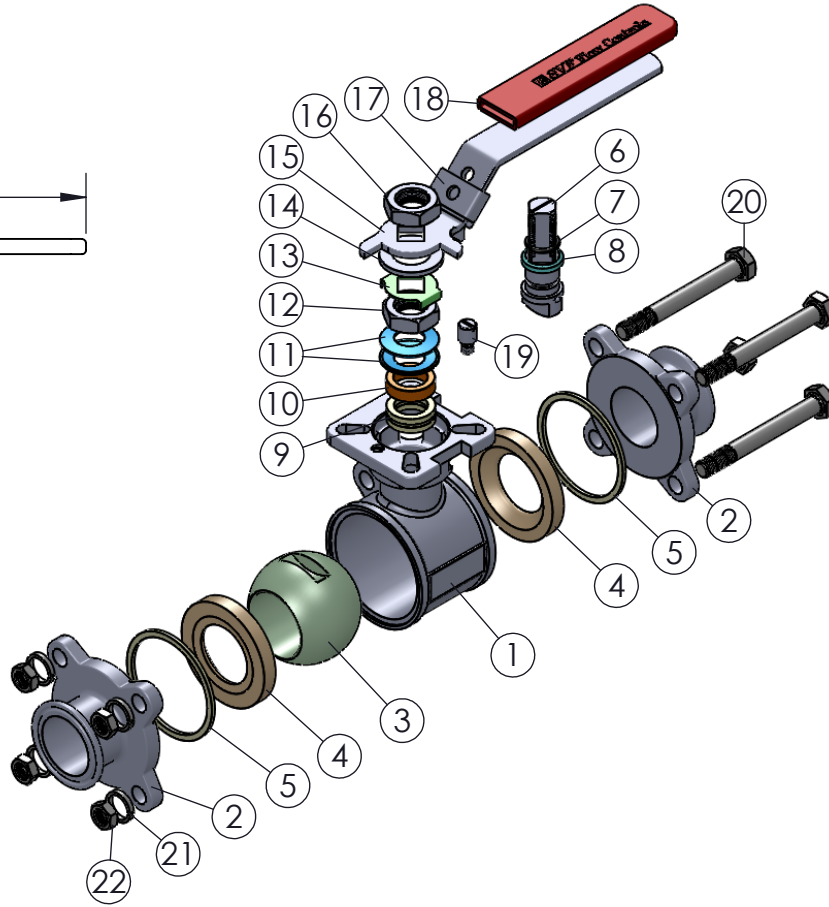
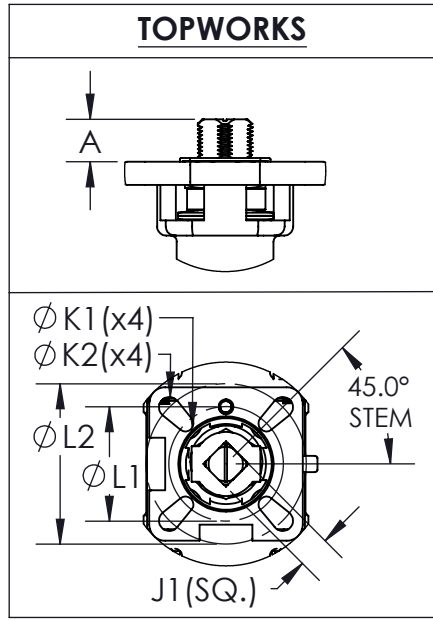
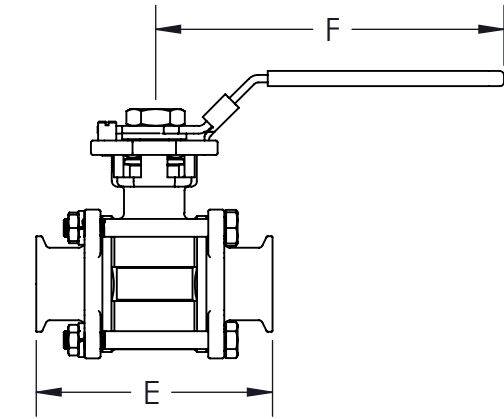
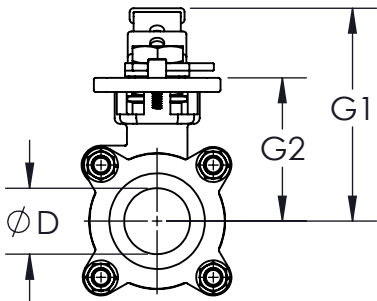

- PRODUCT INFORMATION:**
1. BLOW-OUT PROOF STEM
 2. LOCKING DEVICE
 3. ANTI-STATIC DEVICE
 4. LIVE LOADING STEM SEAL
 5. INTERNAL SURFACE FINISH OF 20 Ra
 6. COMPLETE VALVE AUTOMATION

- APPLICABLE STANDARDS:**
1. ASME B16.34: DESIGN
 2. ISO 5211: MOUNTING
 3. API 598: INSPECTION AND TESTING
 4. CGA G-4.1: CLEANING FOR OXYGEN SERVICE
 5. USP CLASS VI: CONFIRMATION OF COMPLIANCE (PTFE MATERIAL)

4" VALVE WITH PIPE HANDLE: END CONFIGURATION:

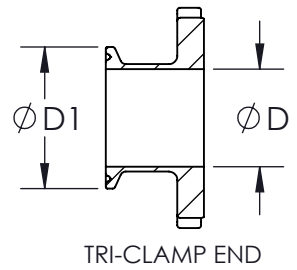
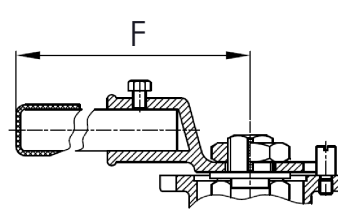

ITEM NO.	DESCRIPTION	MATERIALS	QTY.
1	BODY	A351-CF8M	1
2	END	A351-CF8M	2
3	BALL	A351-CF8M	1
4	SEAT	PTFE	2
5	BODY SEAL	PTFE	2
6	STEM	A276-316	1
7	STEM O-RING	VITON	1
8	STEM THRUST WASHER	TFM4215	1
9	STEM SEAL	PTFE	3
10	GLAND FOLLOWER	304 STAINLESS STEEL	1
11	BELLEVILLE WASHER	301 STAINLESS STEEL	2
12	JAM NUT	304 STAINLESS STEEL	1
13	LOCK TAB	304 STAINLESS STEEL	1
14	SPACER	304 STAINLESS STEEL	1
15	LEVER HANDLE	304 STAINLESS STEEL	1
16	HANDLE NUT	304 STAINLESS STEEL	1
17	LOCKING DEVICE	304 STAINLESS STEEL	1
18	HANDLE SLEEVE	PLASTIC	1
19	STOP PIN	304 STAINLESS STEEL	1
20	BODY BOLT	304 STAINLESS STEEL	4
21	SPRING WASHER	304 STAINLESS STEEL	4
22	BODY NUT	304 STAINLESS STEEL	4

DRAWN BY E.P. DATE 06/01/2017
 CHECKED BY E.G. DATE 03/22/2018
 APPROVED BY J.S. DATE 03/22/2018
(FOR REF. ONLY IF NOT APPROVED)

THE INFORMATION CONTAINED IN THIS DRAWING IS THE SOLE PROPERTY OF SVF FLOW CONTROLS, INC. ANY REPRODUCTION IN PART OR IN WHOLE WITHOUT THE WRITTEN CONSENT OF SVF FLOW CONTROLS, INC. IS PROHIBITED.

PROJECTION THIRD ANGLE

SVF FLOW CONTROLS

DESCRIPTION: 1/2" - 4" SB9B 3-PIECE SANITARY BALL VALVE, TRI-CLAMP ENDS

UNITS: INCH (MILLIMETERS) DATE: 03/22/2018 REV: D