

Series B43D Ball Valve

ANSI Class 600 Flanged, Fire-Safe Ball Valve
Sizes 1/2" ~ 8"



The SVF Series B43D Flanged Ball Valves are high performance, Class 600 full ported valves certified to API-607 fire safe design (with GRAFOIL® body seals only) and API-608, ISO TopWorks for actuation and designed for a wide range of industrial applications.

SERIES B43C DESIGN FEATURES

- ✓ Fire-Safe certification to API-607 (with GRAFOIL®, body seals only)
- ✓ Certified to API-608 to meet the additional design, operation and performance requirements of the Petroleum Refining, Petrochemical Processing and Chemical Processing Industries
- ✓ Standard NACE MR 0175
- ✓ ISO 5211 mounting pad for automation
- ✓ Standard seat material is SupraLon for higher temperature, steam and thermal fluid applications
- ✓ Standard Anti-Static stem
- ✓ Standard locking handle in both open and closed positions (1" ~ 4")
- ✓ Worm gear operator handwheel for 6" & 8" valves
- ✓ Blowout proof stem adds safety & reliability

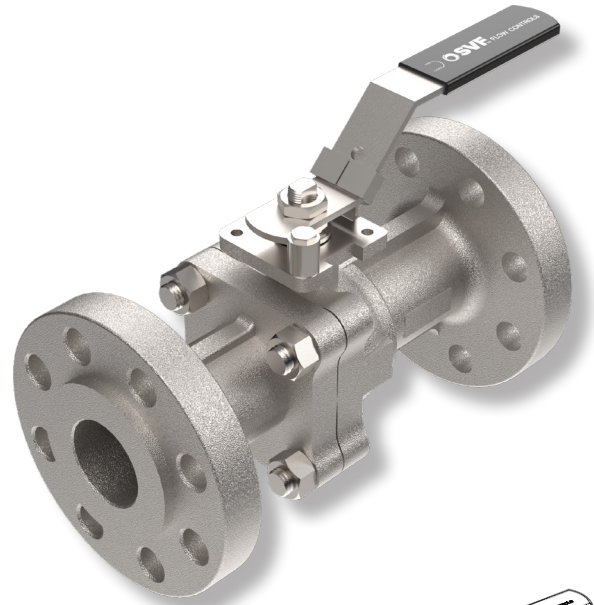

MATERIALS OF CONSTRUCTION

ITEM	DESCRIPTION	MATERIALS SPECIFICATIONS
1	Body	316 Stainless Steel (ASTM A351 CF8M) Carbon Steel (ASTM A216 WCB)
2	End Connector	316L Stainless Steel (ASTM A351 CF8M) Carbon Steel (ASTM A216 WCB)
3	Ball	316 Stainless Steel (ASTM A351 CF8M)
4	Stem	316 Stainless Steel (ASTM A276)
5	Seat	SupraLon™
6	Body Seal	GRAFOIL® + 316 Stainless Steel
7	Stem Seal	GRAFOIL®

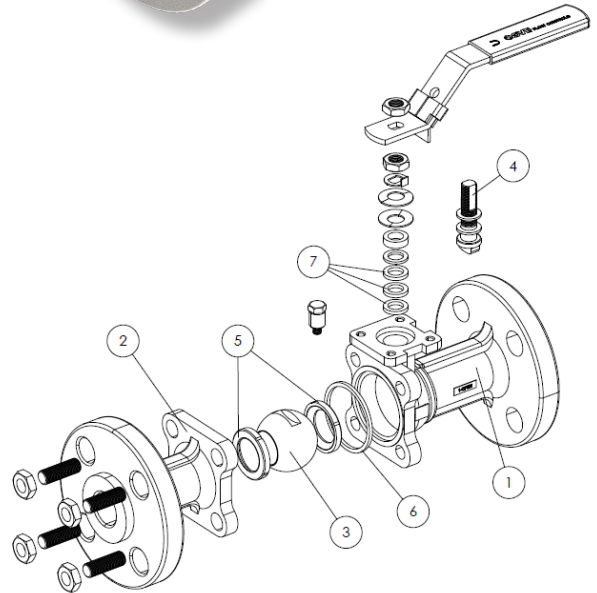

SPECIFICATION STANDARDS OF COMPLIANCE

- Design - ASME B16.34, NACE MR 0175
- Face to Face: ASME B16.10
- End Flange: ASME B16.5
- Wall Thickness: ASME B16.34
- Inspection & Testing: API 598
- Fire Safe: API 607, ISO 10497

What do you need today?™



Series B43D Ball Valve

ANSI Class 600 Flanged, Fire-Safe Ball Valve
 Sizes 1/2" ~ 8"



DIMENSIONS, WEIGHT, CV, TORQUE

Size	A		B		D		L		Weight		Cv	Torque* SupraLon™	
	in.	mm	in.	mm	in.	mm	in.	mm	lbs	kg		in-lbf	Nm
1/2"	6.5	165	0.59	15	5.19	132	3.15	80	7	3	11	97	11
3/4"	7.5	190	0.79	20	5.19	132	3.35	85	11	5	26	177	20
1"	8.5	216	0.98	25	6.54	166	4.02	102	14	6	42	204	23
1-1/2"	9.5	241	1.50	38	7.80	198	4.92	125	29	13	120	611	69
2"	11.5	292	1.97	50	7.80	198	5.20	132	38	17	190	1425	161
3"	14.0	356	2.99	76	11.81	300	7.40	188	78	35	600	1859	210
4"	17.0	432	3.94	100	17.71	450	7.95	202	150	68	1650	2036	230
6"	22.0	559	5.91	150	-	-	20.51	521	536	243	2600	8851	1000
8"	26.0	660	7.91	201	-	-	26.1	664	877	398	4200	19029	2150

B43D - PRESSURE/TEMPERATURE CHART

* At full differential pressure for clean fluids

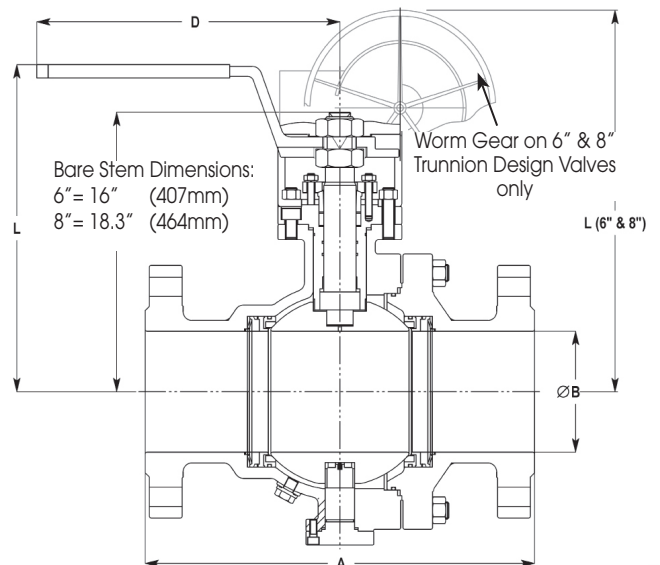
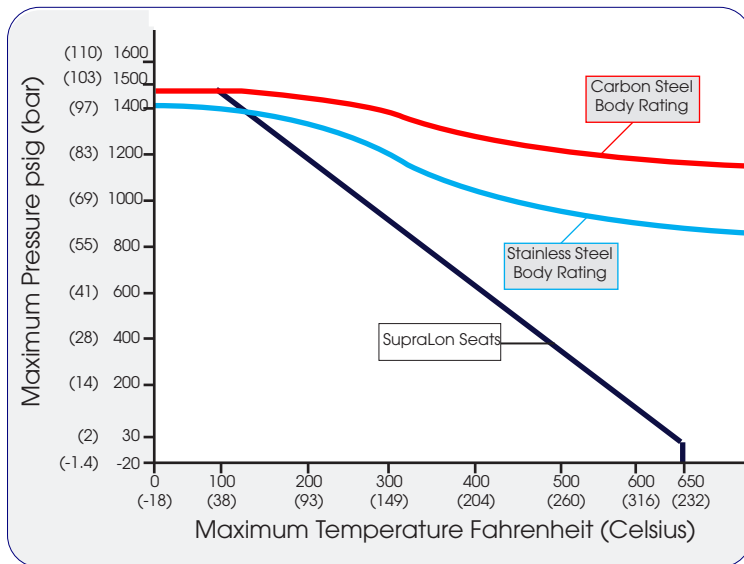

Class 600

Note: Maximum pressure & temperature is limited to the seat material rating

Series B43D Ball Valve

ANSI Class 600 Flanged, Fire-Safe Ball Valve
 Sizes 1/2" ~ 8"



How To Order Guide (Columns 1 thru 11)

1 SERIES	2 BODY	3 ENDS	4 BALL	5 STEM	6 SEAT MATERIAL
B43D	4 = Carbon Steel ASTM A216 WCB 6 = 316 Stainless Steel ASTM A351 CF8M	4 = Carbon Steel ASTM A216 WCB 6 = 316L Stainless Steel ASTM A351 CF8M	6 = 316 Stainless Steel ASTM A351 CF8M	6 = 316 Stainless Steel ASTM A276-316	S = SupraLon™

7 BODY SEAL	8 END CONNECTIONS	9 VALVE SIZE	10 OPTIONS*	11 SPECIAL SERVICES*
G = Grafoil	RF3 = 600# Flanged Ends (Raised Face)	005 = 1/2" 007 = 3/4" 010 = 1" 015 = 1-1/2" 020 = 2" 030 = 3" 040 = 4" 060 = 6" 080 = 8"	00 = None SJ = Steam Jacket (1-1/2" to 8" sizes available)	00 = None XC = Oxygen Cleaned SF = Degreased (Silicone Free) UH = Vent/Relief Hole ¹ AE = Oxygen Cleaned & Vent/Relief Hole ¹ AK = Degreased & Vent/ Relief Hole ¹

Order Example: (B43C6666AGRF30150000) The Part Number will contain 20 digits.

Ordering Code Sequence >>

Sample Part Number >>

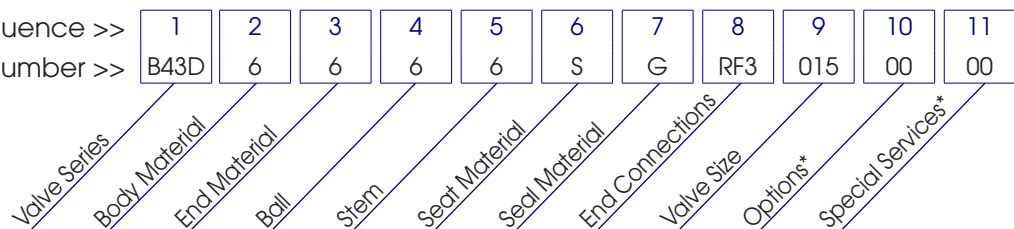

¹ Vent Hole is on the Upstream Side

*Not all Options or Special Services available on all ball valves. Consult SVF for additional information.