

Series *OPUS*™ Ball Valve

CleanFLOW™ High Purity Steam Trap Test Valve
 Sizes 1/2" ~ 2"



CleanFLOW™ *Opus*™ valve is a high performance Steam Trap Test Valve designed exclusively for the high purity, pharmaceutical market. This multifunctional valve provides three states of fluid control. In the normal position, the *Opus* valve delivers full flow of clean steam through our "Tube I.D." porting in accordance with ASME-BPE guidelines for full flow, drainability, surface finish and materials. Two additional flow positions, Service and Trap, provide isolation of system components or the steam trap. In all cases, the *Opus*™ valve utilizes critical orifice designs allowing condensate to reach the steam trap. The integrated design eliminates more complex piping schemes, reduces number of components and delivers overall system value and reliability. All materials are compliant with FDA, USDA and 3A standards.

SERIES *OPUS*™ DESIGN FEATURES

- ✓ High Performance Steam Trap Test Valve with three states of fluid control
- ✓ ASME-BPE compliant
- ✓ Silicone Free
- ✓ Complete 316L Stainless Steel cast construction
- ✓ Drainable design with "Tube-ID" dimensions
- ✓ ISO 5211 mounting pad for easy actuation
- ✓ Encapsulated body seals to facilitate welding without disassembly
- ✓ End connections include Tri-Clamp and Extended Tube O.D.
- ✓ Controlled delta ferrite chemistry
- ✓ Standard interior finish is 15Ra or better
- ✓ ETO ends are designed for Orbital Welding
- ✓ Standard locking device for manual valves
- ✓ For automated systems, 2-position (90 degree) or 3-position (180 degree) can be accomplished by using different controllers (2-stage or 2-wire controller) as well as adapting to Devicenet, ASi or other logic systems

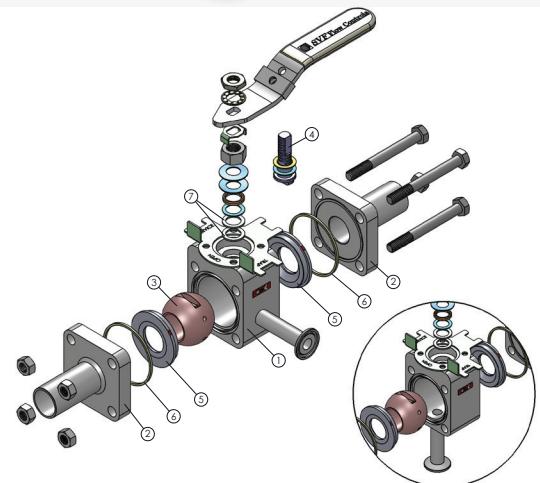

MATERIALS OF CONSTRUCTION

ITEM	DESCRIPTION	MATERIALS SPECIFICATIONS
1	Body	316L Stainless Steel (ASTM A351 CF3MN or ASTM A182-F)
2	End Connector	316L Stainless Steel (ASTM A351 CF3MN or ASTM A182-F)
3	Ball	316L Stainless Steel (ASTM A351 CF3MN or ASTM A182-F)
4	Stem	316L Stainless Steel (ASTM A351 CF3MN or ASTM A182-F)
5	Seat	TFM1600™
6	Body Seal	PTFE
7	Stem Seal	TFM1600™

There are no elastomers used for any of the components on the *OPUS*™ valves. Only PTFE and TFM are used for seats and seals.

What do you need today?™



Series OPUS™ Ball Valve

CleanFLOW™ High Purity Steam Trap Test Valve

Sizes 1/2" ~ 2"



SERVICE POSITION

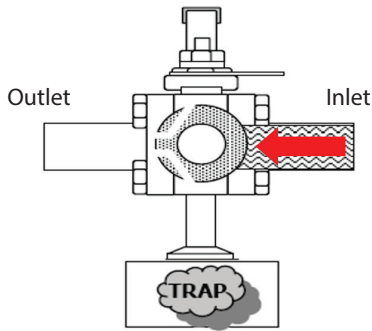

Allows for maintenance of the steam trap by rotating the handle to the Service Position.

In the Service Position, the steam trap is isolated from the steam, allowing the trap to be removed for maintenance.

Once service is completed, return the handle to the Trap or Open Position, based on your needs.

OPEN POSITION

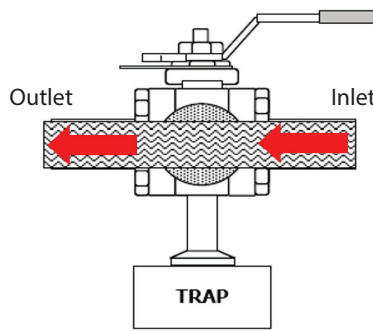

Allows the flow of steam without utilizing the steam trap.

In the Open Position, the steam trap is isolated from the flow allowing sterilization temperature to be reached.

To utilize the steam trap, rotate the handle to the Trap Position. For service, rotate the handle to the Service Position.

TRAP POSITION

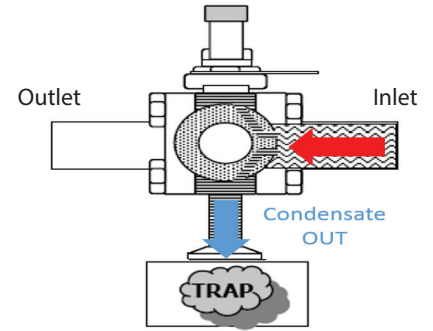

Allows condensate to flow past the ball purge holes during normal operation, by-passing the upstream seat.

In the Trap Position the valve body cavity remains hot.

The point-of-use or sampling connection is isolated by the ball surface.

OPUS™ PRESSURE/TEMPERATURE CHART

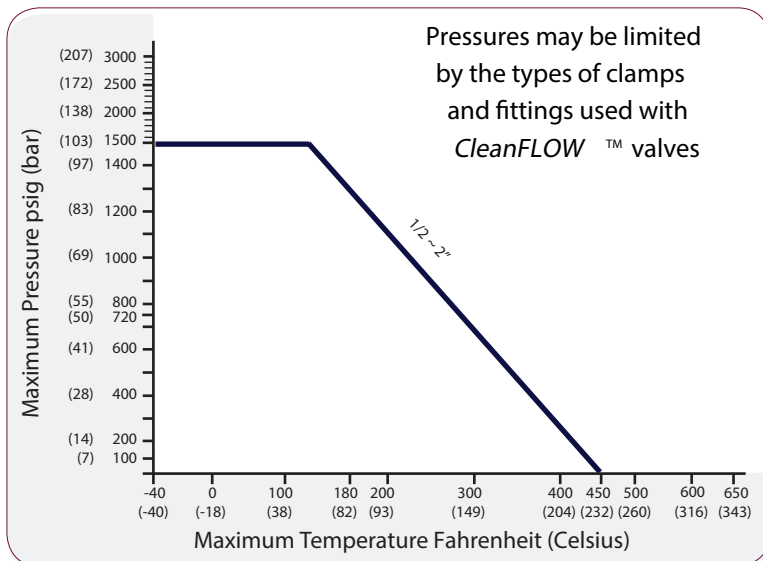

Class 600 (Sizes: 1/2" to 2")

MANUAL OPERATION - TOP VIEW

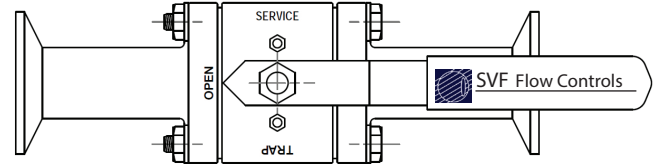

NOTE: The valve operates in the clockwise direction from the "Trap" position to the "Open" position and to the "Service" position.

Automated valves will use a 180 degree actuator to provide full stroke.

A controller, fitted to the top of the actuator, will provide the logistics to achieve the three independent stop points.

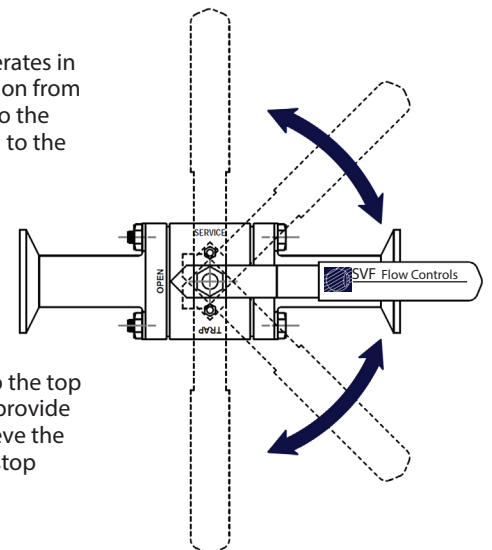

Series OPUS™ Ball Valve

CleanFLOW™ High Purity Steam Trap Test Valve

Sizes 1/2" ~ 2"



DIMENSIONS, WEIGHT, C_v, TORQUE

Size	A-1		A-2		B-1		C		D		L		W-1		W-2		Weight		C _v	Torque*	
	in.	mm	in.	mm	in.	mm	in.	mm	in.	mm	in.	mm	in.	mm	in.	mm	lbs	kg		in-lbf	Nm
1/2"	5.50	140	3.50	89	0.37	9	2	50	5	127	2.22	56	0.065	1.7	0.065	1.7	2	0.9	8	60	7
3/4"	6.00	152	4.00	102	0.62	16	2	50	5	127	2.28	58	0.065	1.7	0.065	1.7	2	0.9	29	60	7
1"	6.50	165	4.50	114	0.87	22	2	50	6	152	2.56	65	0.065	1.7	0.065	1.7	4	1.8	66	100	11
1-1/2"	7.50	191	5.50	140	1.37	35	2	50	7	178	3.09	78	0.065	1.7	0.065	1.7	8	3.6	192	200	23
2"	8.00	203	6.25	159	1.87	47	2	50	7	178	3.45	88	0.065	1.7	0.065	1.7	13	5.9	434	250	28

Bottom Port Downstream
Steam Trap Port Location

*At full differential pressure

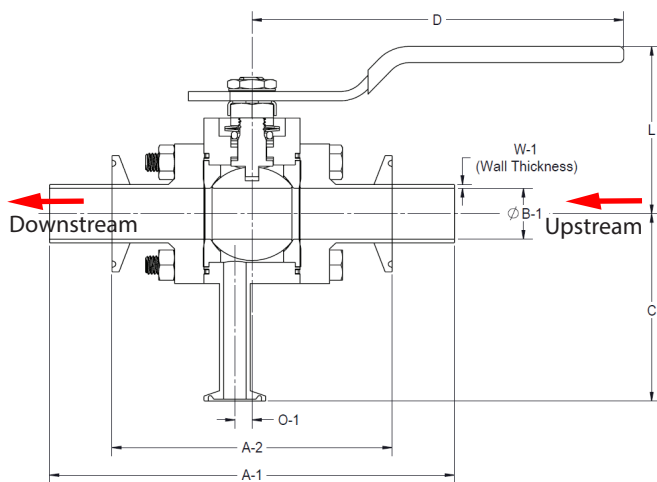

Bottom Port Center
Steam Trap Port Location

*At full differential pressure

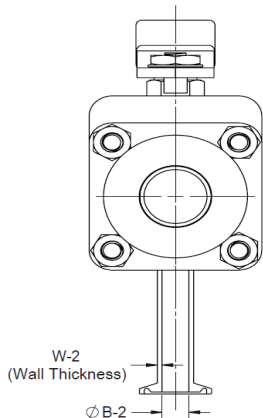
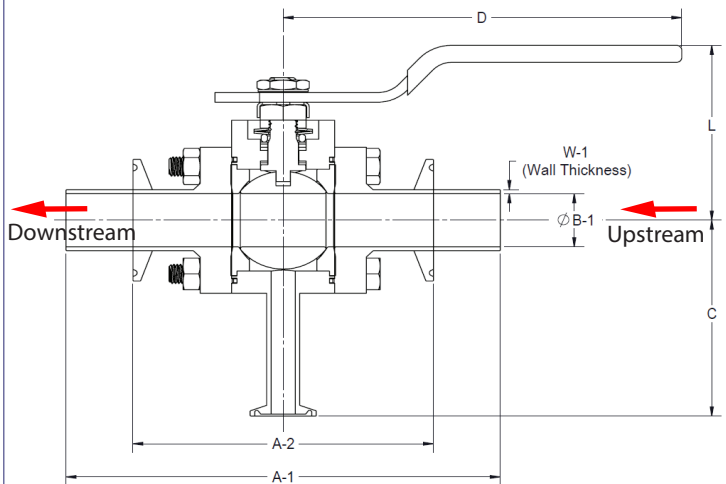

Size	1/2" Purge Port		3/4" Purge Port		1" Purge Port	
	Ø B-2	O-1	Ø B-2	O-1	Ø B-2	O-2
	in.	in.	in.	in.	in.	in.
1/2"	0.37	0.12	0.62	-	0.87	-
3/4"	0.37	0.12	0.62	-	0.87	-
1"	0.37	0.32	0.62	0.20	0.87	0.07
1-1/2"	0.37	0.55	0.62	0.43	0.87	0.30
2"	0.37	0.77	0.62	0.65	0.87	0.52

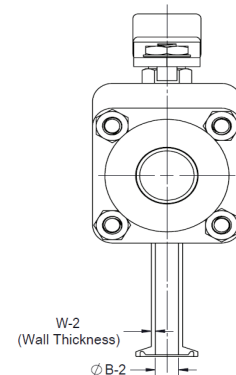

Series *OPUS*™ Ball Valve

CleanFLOW™ High Purity Steam Trap Test Valve
 Sizes 1/2" ~ 2"



How To Order Guide (Columns 1 thru 11)

1 SERIES	2 BODY & ENDS	3 BALL & STEM	4 SEAT & SEAL	5 END CONNECTIONS	6 STEAM TRAP CONNECTION
SC00 = (Cast) SF00 = (Forged)	6 = 316L Stainless Steel ASTM A351 CF3MN or A182-F	6 = 316L Stainless Steel ASTM A351 CF3MN or A182-F	AT = TFM1600™ Seats & PTFE Seals (for Cast) AA = TFM1600™ Seats & Seals (for Forged)	TR0 = Tri-Clamp Ends ETO = Extended Tube O.D. Ends	T = Tri-Clamp Ends

7 STEAM TRAP PORT LOCATION	8 STEAM TRAP PORT SIZE	9 VALVE SIZE	10 OPTIONS*	11 SPECIAL SERVICES*
5 = Bottom Port Downstream Side 6 = Bottom Port Centered Point	A = 1/4" B = 3/8" C = 1/2" D = 3/4" E = 1"	005 = 1/2" 007 = 3/4" 010 = 1" 015 = 1-1/2" 020 = 2"	00 = None	00 = None XC = Oxygen Cleaned EP = Electropolished SB = 10Ra ID Finish SC = 5 Ra ID Finish AA = Electropolished & 15Ra ID Finish AB = Electropolished & 10Ra ID Finish AC = Electropolished & 5Ra ID Finish AD = Oxygen Cleaned & Electropolished

Order Example: (SC0066ATTR0T5A0050000) The Part Number will contain 21 digits.

Ordering Code Sequence >>

Sample Part Number >>

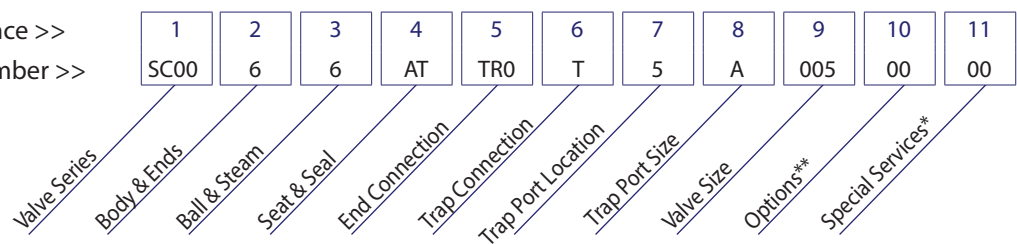

*Not all Options or Special Services available on all ball valves. Consult SVF for additional information.