

INSTALLATION, OPERATION & MAINTENANCE FOR SVF TSB7F SERIES FORGED BALL VALVES

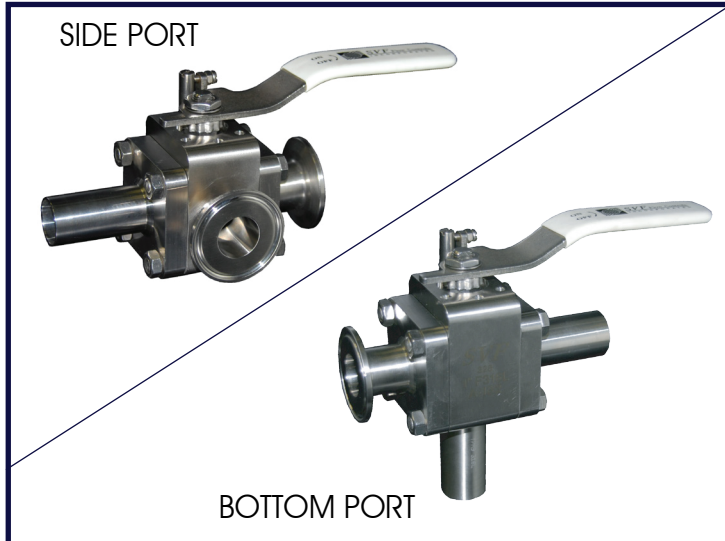

!!!CAUTION! Safety Precautions!!!

Before removing valve from pipeline NOTE that:

Media flowing through a valve may be corrosive, toxic, flammable, a contaminant or harmful nature. Where there is evidence of harmful fluids having flowed through the valve, the utmost care must be taken. It is suggested that the following minimal safety precautions be taken when handling valves.

1. Always wear eye shields.
2. Always wear gloves and overalls.
3. Wear protective footwear.
4. Wear protective headgear.
5. Ensure that running water is readily accessible.
6. Have a suitable fire extinguisher ready if media is flammable.
7. Be sure that you are aware of the fluid that has been passing through the valve before opening or dismantling any valve. Require MSDS information.

By checking line gauges ensure that no pressure is present at the valve.

Ensure that any media is released by operating valve slowly to half open position. Ideally, the valve should be decontaminated when the ball is in the half open position.

These valves, when installed, have body connectors which form an integral part of the pipeline and the valve cannot be removed from the pipeline without being dismantled.

Valves and accessories must not be used as a sole support of piping or human weight. Safety accessories such as safety relief (overpressure) valves are the responsibility of the system designer.

It is the user/system designer's responsibility to use insulation in high temperature applications. Refer to OSHA documents for more details.

GENERAL

SVF Ball valves have been designed and engineered to provide long lasting and trouble free service when used in accordance with the instructions and specifications herein.

The following instructions refer only to SVF CleanFLOW™ Series TSB7F Forged Ball Valves.

Keep protective cover in place until moment of installation. Valve performance depends upon prevention of damage to ball surface. Upon removal of cover, make sure that the valve is completely open and free of obstruction.

STORAGE:

All manual valves are shipped in the fully open position with protective end caps (covers). Keep all protective packaging, flange covers, or end caps attached to the valves during storage. To avoid damage to the seat due to contact with the balls edge, leave the valve in the **fully open or closed position** during storage. It is recommended to keep the valves in a clean and dry environment until ready for use.

What do you need today?™

HIGH PURITY
CleanFLOW®

PRO-SPEC
PROCESS SPECIFIC
WWW.PRO-SPEC.NET

QUALITY FLOWS
THROUGH US

Please visit www.SVF.net for the latest updates on this document. All data posted on our website supersede all prior publications • [Document #SVF_TSB7F_IOM - 10/23/2015]

www.SVF.net

SVF Flow Controls, Inc. • 13560 Larwin Circle • Santa Fe Springs, CA 90670 • Tel: 1.800.783.7836 • FAX: 562.802.3114
Sales@SVF.net • Visit our website: www.SVF.net • © SVF Flow Controls, Inc. • Specifications subject to change without notice

INSTALLATION, OPERATION & MAINTENANCE FOR SVF TSB7F SERIES FORGED BALL VALVES

INSTALLATION

The valve may be installed for flow or vacuum in either direction. Carefully exclude pipe sealants from the valve cavity. When installing, use standard gaskets suitable for the specific service. Tighten flange bolts or studs evenly.

OPERATION

SVF valves provide tight shut off when used under normal conditions and in accordance with SVF's published pressure/temperature chart. If these valves are used in a partially open (throttled) position seat life may be reduced.

SVF valves have ¼ turn operation closing in a clockwise direction. It is possible to see when the valve is open or closed by the position of the wrench handle. When the wrench is inline with the pipeline, the valve is open.

Any media which might solidify, crystallize or polymerize should not be allowed to stand in the ball valve cavities unless regular maintenance is provided. If minimal maintenance is required, SVF offers steam jacketed ball valves.

TORQUE REQUIREMENTS

Torque ratings are subject to variations depending on the length of time between cycles and the media in the system.

Breakaway torque is that force which must be exerted to cause the ball to begin to open. Operating torque requirements will vary depending on the length of time between cycles, media in the system, line pressure, and type of valve seat.

MAINTENANCE

With self-wiping ball/seats, SVF valves have a long, trouble free life, and maintenance is seldom required. But, when necessary, valves may be refurbished, using a small number of components, none of which require machining.

SVF valves are designed for easy service and assembly in the field. The following checks will help to extend valve life, or reduce plant problems.

SVF ball valves utilize live-loaded stem seals featuring Belleville Washers (disk springs) that maintain constant pressure on the Stem Seal area even under a wide range of pressure and temperature fluctuations. If stem leakage is evident proceed as follows:

STEM LEAKAGE

Examine the disk springs (Belleville Washers) for damage. If in good condition tighten the gland nut until disk springs are firmly compressed, then back nut off 1/16th of a turn. If damaged, dismantle the stem down to the gland, fit new disk springs with their outer edges touching, replace and retighten using gland nut. Further maintenance necessitates dismantling of the valve.

LEAKAGE AT BODY JOINT

Check for tightness at the body connector bolts. If loose, tighten body bolts. Excessive force will damage the bolts. (See Table A below) If there is still leakage it will be necessary to dismantle the valve and replace the body seals.

IN-LINE LEAKAGE

Check that the valve is fully closed. If leakage occurs while the valve is in the closed position, a seat or ball sealant surface may be damaged and it will be necessary to disassemble the valve.

NOTE: Stem leakage and leakage at body joint, if not cured by simple means described above, necessitate dismantling valve. If there is no stem leakage the stem assembly should not be touched.

INSTALLATION, OPERATION & MAINTENANCE FOR SVF TSB7F SERIES FORGED BALL VALVES

REBUILDING

Before rebuilding, check that all the correct components are available and that they are fit for reassembly. When rebuilding, cleanliness is essential to allow long valve life and provide cost effective maintenance. CAUTION: NO BODY OR STEM SEALS ARE REUSABLE. Care must be taken to avoid scratching the seats and seals during installation.

NOTES:

1. Caution must be taken with valves that have been in hazardous media. They must be decontaminated before disassembly, by relieving the line pressure and flushing the line with the valve in the partially open position. Protective clothing, face shields, gloves, etc., MUST BE USED for this operation.
2. The TSB7F valves has a tongue and groove seal design and cannot be repaired inline. The valve must be removed from the line to be disassembled.

A DISASSEMBLY OF VALVE (Removed from line)

- 1.) Remove the End Connectors (#2) by removing the Body Bolts (#16) and Body Bolt Nuts (#17).
- 2.) Once the End Connectors (#2) have been separated from the Body (#1), remove the Body Seals (#6) and Seats (#5).
- 3.) Make sure the Ball is in the closed position, thus the Ball (#3) can be removed easily from the Body (#1).

B REMOVING STEM ASSEMBLY - 1/2" ~ 2"***

Refer to drawing on Page 5

- 1.) Remove Handle (#13) by removing Handle Nut (#15) along with the Lock Washer (#14).
- 2.) Remove the Locking Arm (#12), Tab Lock (#11), Stem Nut (#10), Belleville Washers (#9), Gland (#8), Stem Seals (#7) and Thrust Washer (#7A).
- 3.) Push the Stem (#4) down into the body cavity to remove. Once removed take off the Thrust Washers (#7A and #21).

B-1 REMOVING STEM ASSEMBLY - 2-1/2" ~ 4" **

Refer to drawing on Page 6

- 1.) Loosen Handle Bolt (#16) on Handle Adapter (#14) to remove the Pipe Handle (#15).

- 2.) Remove Tab Lock (#11), Stem Nut (#10), Belleville Washers (#9), Stopper (#13), Gland (#8), Stem Seals (#7) and Stem Locating Ring (#12).
- 3.) Push the Stem (#4) down into the body cavity to remove. Once removed take off the Thrust Washers (#19 and #19A).

C INSPECTION

- 1.) The ball and the surfaces of the seats should be free of pit marks and scratches. Light marring from the action of the ball against the seats is normal and will not affect the operation of the valve.
2. The stem, thrust bearing, stem seal, and surrounding body should be free of pit marks and scratches.

D REASSEMBLY - 1/2" ~ 4"

- 1.) Refer to "REMOVING STEM ASSEMBLY" (Per Valve Size) listed in the column on the left of this page. Follow the reverse order for Reassembly.
- 2.) When stem assembly is complete, tighten Stem Nut according to the values in Table A.
- 3.) With the Stem (#4) in the closed position (the flat sides of the Stem (#4) must be parallel to the body seal grooves of the Body #1), insert the respective 3-Way Ball into the Body (#1) so that the stem slot of the Ball engages with the tang at the base of the Stem. NOTE: Make sure the 3-Way Ball is configured to the proper flow pattern. Refer to Ball Configurations on Page 7.
- 4.) Make sure Body Seals (#6) rest squarely on center seal surface of the body.
- 5.) Insert seats in body. Make sure seats rest firmly on back surface of each recess.
- 6.) Merge the End Connectors (#2) with the body (#1).
- 7.) Insert and tighten Body Bolts/Nuts (#16 for sizes 1/2" ~ 2"; #17 for sizes 2-1/2" ~ 4") diagonally, in accordance to the cross pattern procedure shown on the following page.
- 8.) In the final assembly step ensure that Body Bolts/Nuts are tightened according to torques values in Table A.

continued >

**** Reassemble in Reverse Order.**

INSTALLATION, OPERATION & MAINTENANCE FOR SVF TSB7F SERIES FORGED BALL VALVES

TORQUE SPECS

Certain precautions need to be followed when tightening bolts down to their corresponding torques to help prevent bolt galling. There are two passes each bolt has to undergo during the process, first pass and the final pass. Once every bolt has met the first pass requirement, the final pass can be initiated. When tightening down bolts it is necessary to follow the corresponding bolt pattern shown below.

TABLE A: TORQUE REQUIREMENTS (in-lbs)

Valve Size	Bolt Pattern	Body Bolts		Stem Nuts
		First Pass	Final Pass	
1/2"	4	48	80	35
3/4"	4	48	80	35
1"	4	101	168	80
1-1/2"	4	207	345	115
2"	4	207	345	115
2-1/2"	8	207	345	265
3"	8	207	345	530
4"	8	346	576	530

REPAIR KITS

Repair Kits are available from SVF Flow Controls, Inc. Table B below shows what the kits consist of. When ordering a Repair Kit, please be sure to specify the type, size and seat material of the valve.

When repairing a valve use only SVF Flow Controls, Inc. authorized spare parts including bolts and nuts, etc. In addition to maintenance kits, spare parts are available from SVF Flow Controls, Inc. (balls and stems). If additional parts are required (body and ends) it is normally recommended that the complete valve be replaced.

Components from a different valve series should not be used with the repair of any other valve. If the valve is altered in any way, no liability can be accepted by SVF Flow Controls, Inc.

TABLE B: GENERAL REPAIR KIT

Part	Quantity
Thrust Washer	3 (2 on sizes 2-1/2" ~ 4")
Stem Seals	2 (3 on sizes 2-1/2" ~ 4")
Belleville Washers	2
Seats	2
Body Seals	2
Gland	1

TSB7F SERIES BOLT PATTERNS - BOLT TIGHTENING SEQUENCE

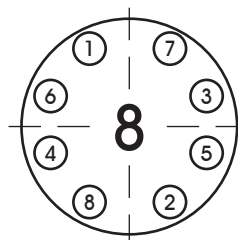
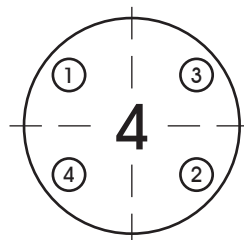

MATERIALS OF CONSTRUCTION FOR SVF TSB7F SERIES FORGED BALL VALVES SIZES 1/2" ~ 2"

Item #	Part Name	Materials	Recommended Spare	Wetted
1	Body	316L Stainless Steel ASTM A182-F	-	X
2	End Connector	316L Stainless Steel ASTM A182-F	-	X
3	Ball	316L Stainless Steel ASTM A182-F	-	X
4	Stem	316L Stainless Steel ASTM A276-316L	X	X
5	Seat	TFM1600™	X	X
6	Body Seal	TFM1600™	X	X
7	Stem Seal	TFM1600™	X	X
7A	Thrust Washer	Virgin PEEK	X	X
8	Gland	316 Stainless Steel	X	-
9	Belleville Washers	17-7 pH	X	-
10	Stem Nut	Stainless Steel	-	-
11	Tab Lock	Stainless Steel	-	-
12	Locking Arm	Stainless Steel	-	-
13	Handle	Stainless Steel	-	-
14	Lock Washer	Stainless Steel	-	-
15	Handle Nut	Stainless Steel	-	-
16	Body Bolt	SS 304 (A2-70)	-	-
17	Body Bolt Nut	SS 304 (A2-70)	-	-
18	Stop Pin	Stainless Steel	-	-
19	Locking Plate*	304 Stainless Steel	-	-
20	Locking Plate Bolt	Stainless Steel	-	-
21	Thrust Washer	TFM1600™	X	X

*Optional

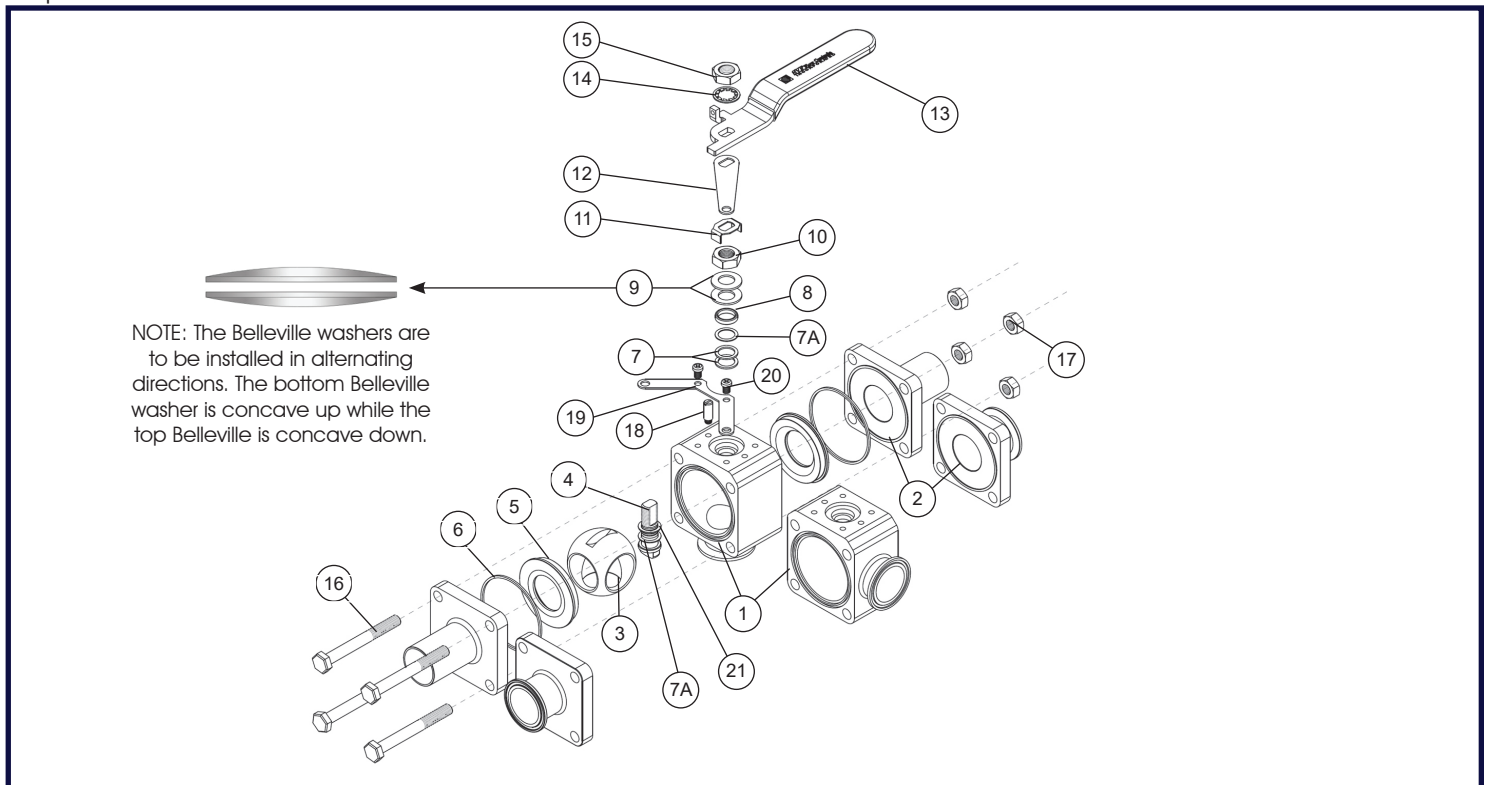

MATERIALS OF CONSTRUCTION FOR SVF TSB7F SERIES FORGED BALL VALVES SIZES 2-1/2" ~ 4"

Item #	Part Name	Materials	Recommended Spare	Wetted
1	Body	316L Stainless Steel ASTM A182-F	-	X
2	End Connectors	316L Stainless Steel ASTM A182-F	-	X
3	Ball	316L Stainless Steel ASTM A182-F	-	X
4	Stem	316L Stainless Steel ASTM A276-316L	-	X
5	Seat	TFM1600™	X	X
6	Body Seals	TFM1600™	X	X
7	Stem Seals	TFM1600™	X	X
8	Gland	316 Stainless Steel	X	-
9	Belleilve Washers	Stainless Steel	X	-
10	Stem Nut	Stainless Steel	-	-
11	Tab Lock	Stainless Steel	-	-
12	Stem Location Ring	Stainless Steel	-	-
13	Stopper	Stainless Steel	-	-
14	Pipe Handle Adapter	Stainless Steel	-	-
15	Pipe Handle	Stainless Steel	-	-
16	Handle Nut/Set Screw	Stainless Steel	-	-
17	Body Bolts	SS304 (A2-70)	-	-
18	Stop Pin	Stainless Steel	-	-
19	Thrust Washer	TFM1600™	X	X
19A	Thrust Washer	Virgin PEEK	X	X

NOTE: The Belleville washers are to be installed in alternating directions. The bottom Belleville washer is concave up while the top Belleville is concave down.

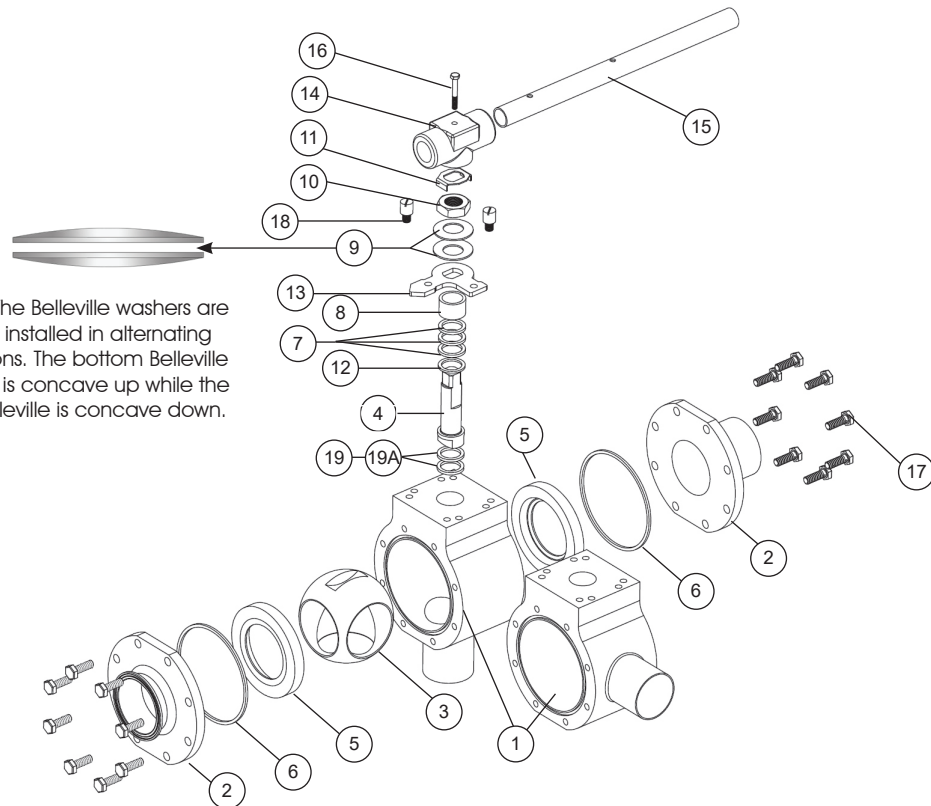

TSB7F COMMON FLOW PATHS

At the heart of the design is the use of a common port that facilitates directional flow requirements and drainability in the optimal position.

The common port "C" may be located at the bottom or the side of the valve. The two most common flow paths are the Side Ported (SL) and the Bottom Ported (BL)*.

SL (L-HORIZONTAL) - SIDE PORTED

This position utilizes an "L-Port" ball and requires quarter-turn operation.

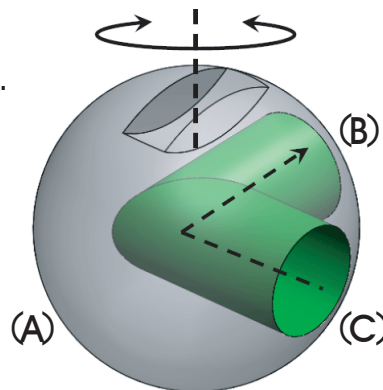
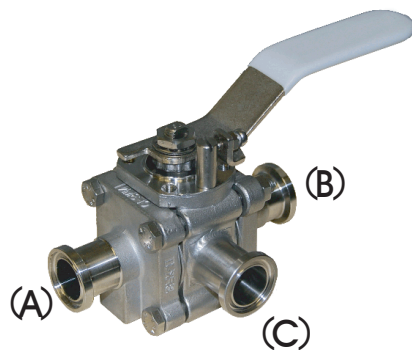

Position (1)
Flow (C to B)

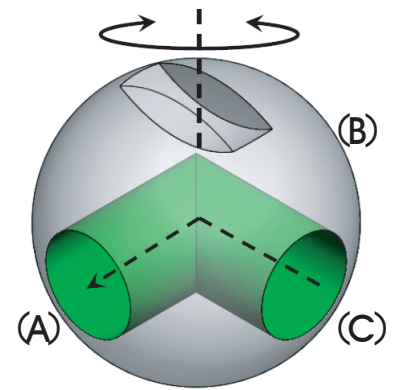

Position (2)
Flow (C to A)

BL (LL) - BOTTOM PORTED

This position utilizes an "LL-Port" ball and requires quarter-turn operation.

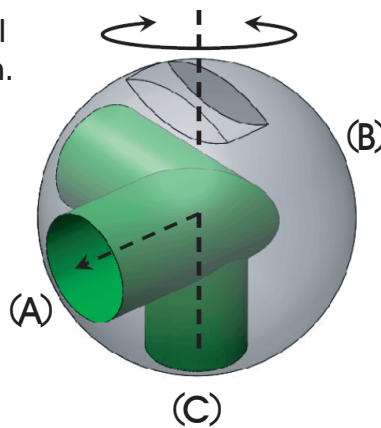
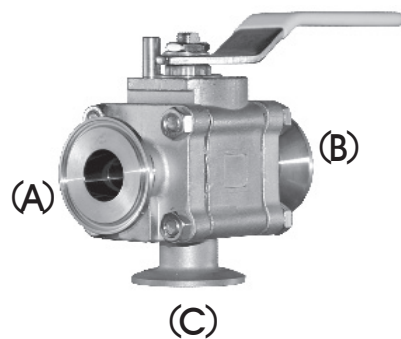

Position (1)
Flow (C to A)

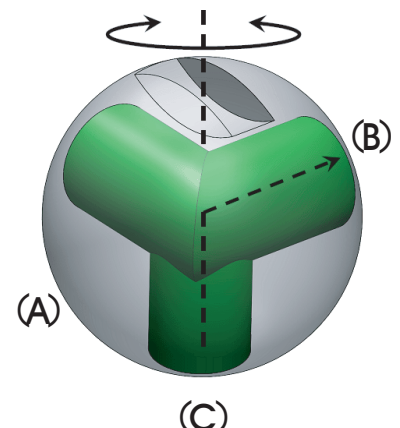

Position (2)
Flow (C to B)

*Other flow paths are available.