

\* AT FULL DIFFERENTIAL PRESSURE FOR CLEAN FLUIDS WITH TFM1600 SEATS

SIZE	A	øB	C	øD	E	F1	F2	G1	G2	H1	øH2	J1	J2	K	øL	øM	END THREAD	ISO 5211	WEIGHT (lbs)	Cv	TORQUE* (in-lbf)	BODY BOLT SIZE	BODY NUT SIZE
1/4"	0.21 (5)	1.0 (25)	0.37 (9)	0.26 (7)	3.03 (77)	5.0 (127)	2.0 (48)	1.8 (46)	3.2 (82)	1.5 (38)	1.8 (46)	0.22 (6)	0.37 (9)	M5-0.8	1.42 (36)	0.25 (6)	7/16"-20	F03	2	3	45	M6-1.0 X 45	M6-1.0P
3/8"	0.21 (5)	1.0 (25)	0.37 (9)	0.38 (10)	3.11 (79)	5.0 (127)	2.0 (48)	1.8 (46)	3.2 (82)	1.5 (38)	1.8 (46)	0.22 (6)	0.37 (9)	M5-0.8	1.42 (36)	0.38 (10)	9/16"-20	F03	2	5	45	M6-1.0 X 45	M6-1.0P
1/2"	0.21 (5)	1.0 (25)	0.37 (9)	0.51 (13)	3.35 (85)	5.0 (127)	2.0 (48)	1.8 (46)	3.2 (82)	1.5 (38)	1.8 (46)	0.22 (6)	0.37 (9)	M5-0.8	1.42 (36)	0.50 (13)	3/4"-20	F03	2	8	45	M6-1.0 X 45	M6-1.0P
3/4"	0.23 (6)	1.0 (25)	0.37 (9)	0.76 (19)	3.74 (95)	5.0 (127)	2.0 (48)	1.9 (48)	3.3 (84)	1.5 (38)	1.8 (46)	0.22 (6)	0.37 (9)	M5-0.8	1.42 (36)	0.75 (19)	1"-20	F03	2	12	45	M6-1.0 X 50	M6-1.0P
1"	0.34 (9)	1.2 (30)	0.70 (18)	1.01 (26)	4.53 (115)	6.0 (152)	2.0 (48)	2.4 (61)	3.7 (94)	1.7 (43)	2.1 (53)	0.30 (8)	0.43 (11)	M5-0.8	1.65 (42)	1.00 (25)	1-5/16"-20	F04	4	32	100	M8-1.25 X 65	M8-1.25P

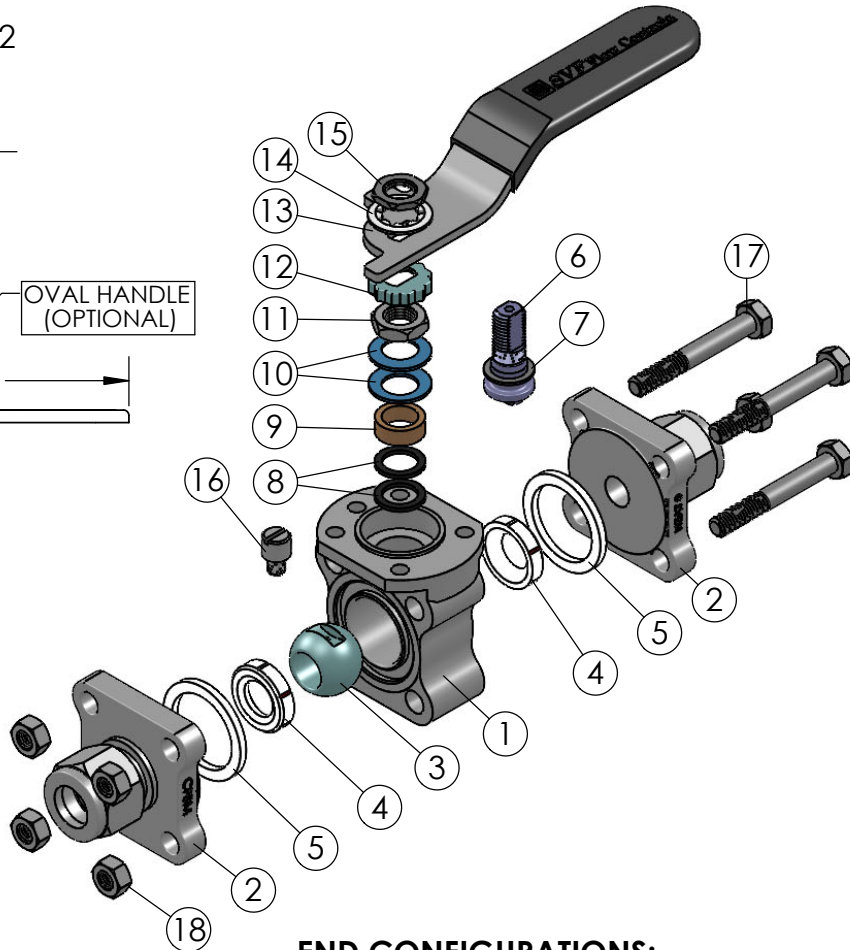

**END CONFIGURATIONS:**

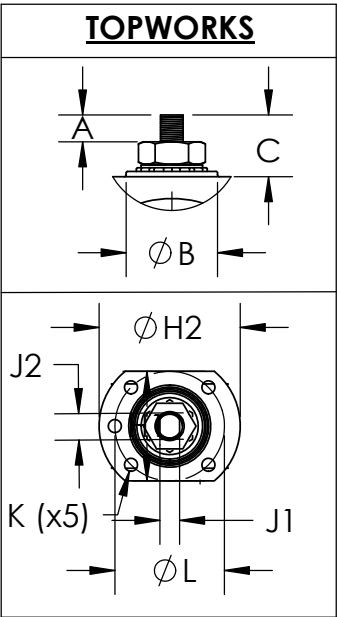
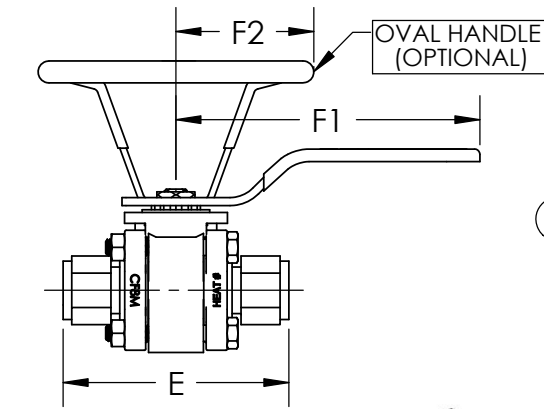
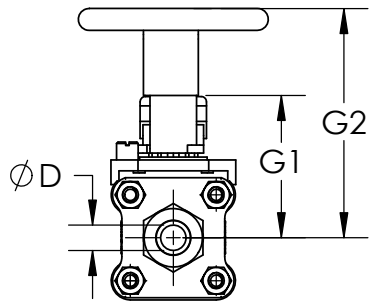
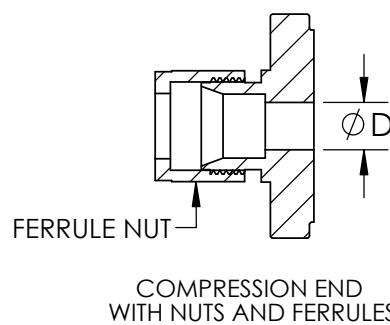
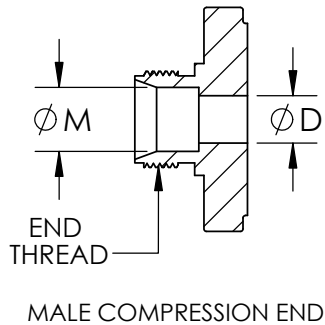

**PRODUCT INFORMATION:**

1. END CONNECTIONS AVAILABLE IN: MALE COMPRESSION AND COMPRESSION WITH NUTS AND FERRULES
2. SERVICES INCLUDE: OXYGEN CLEANING, DEGREASING, VENT/RELIEF HOLE, HIGH CYCLE STEM KIT, AND VACUUM & SEARCHING GAS STEM KIT
3. BALL IS VENTED ON THE STEM SLOT AREA
4. ALL STAINLESS STEEL PASSIVATED
5. LIVE-LOADED STEM SEAL
6. BLOW OUT PROOF STEM
7. COMPLETE VALVE AUTOMATION

**OPTIONS:**

1. OVAL HANDLE
2. LOCKING DEVICE
3. ISO STEM EXTENSION
4. ANTI-STATIC DEVICE

**APPLICABLE STANDARDS:**

1. ASME B16.34: DESIGN
2. API 598: INSPECTION AND TESTING
3. ISO 5211: MOUNTING
4. CGA G-4.1: CLEANING FOR OXYGEN SERVICE
5. USP CLASS VI: CONFIRMATION OF COMPLIANCE (TFM1600/PTFE MATERIAL)

ITEM NO.	DESCRIPTION	MATERIALS	QTY.
1	BODY	A351-CF8M	1
2	END	A351-CF3M	2
3	BALL	A351-CF8M	1
4	SEAT	TFM1600 DELRIN UHMWPE PEEK	2
5	BODY SEAL	PTFE BUNA "N" UHMWPE VITON EPDM	2
6	STEM	A276-316 A564-630	1
7	STEM THRUST WASHER	SUPRALON DELRIN PEEK UHMWPE	1
8	STEM SEAL	SUPRALON	2
9	GLAND FOLLOWER	304 STAINLESS STEEL	1
10	BELLEVILLE WASHER	17-7 PH STAINLESS STEEL	2
11	JAM NUT	304 STAINLESS STEEL	1
12	LOCK TAB	304 STAINLESS STEEL	1
13	LEVER HANDLE	304 STAINLESS STEEL	1
14	SERRATED LOCK WASHER	304 STAINLESS STEEL	1
15	HANDLE NUT	304 STAINLESS STEEL	1
16	STOP PIN	304 STAINLESS STEEL	1
17	BODY BOLT	304 STAINLESS STEEL	4
18	BODY NUT	304 STAINLESS STEEL	4

DRAWN BY: E.P. DATE: 05/22/2017  
 CHECKED BY: K.C. DATE: 03/25/2026  
 APPROVED BY: J.S. DATE: 03/25/2026  
(FOR REF ONLY IF NOT APPROVED)

THE INFORMATION CONTAINED IN THIS DRAWING IS THE SOLE PROPERTY OF SVF FLOW CONTROLS, INC. ANY REPRODUCTION IN PART OR IN WHOLE WITHOUT THE WRITTEN CONSENT OF SVF FLOW CONTROLS, INC. IS PROHIBITED.

PROJECTION THIRD ANGLE

**OSVF FLOW CONTROLS**  
 5595 Fresca Drive • La Palma, CA 90623 • 1.800.783.7836  
 www.SVF.net • Sales@SVF.net

DESCRIPTION:  
 1/4" - 1" L8 3-PIECE INSTRUMENTATION BALL VALVE

UNITS: INCH (MILLIMETERS) DATE: 03/25/2026 REV: D