

Series 505F - 8 Globe Valve

Sizes 1/4" ~ 2"
Trim 8



SERIES 505F DESIGN FEATURES

- ✓ Trim 8 - Forged Carbon Steel
- ✓ Class 800
- ✓ Maximum Pressure 1975 psi
- ✓ Maximum Temperature 850°F
- ✓ Bolted bonnet
- ✓ API 602 compliant
- ✓ Standard NACE MRO175



MATERIALS OF CONSTRUCTION

No.	Part	Material
1	Body	A105
2	Seat	STL
3	Disc	13Cr
4	Stem	410
5	Gasket	SS304 Flexible Graphite
6	Bonnet	A105
7	Bolt	B7
8	Packing	Graphite
9	Pin	SS
10	Pkg Press Sleeve	410
11	Live Bolt	B7
12	Pkg Press Plate	A105
13	Hex Nut	2H
14	Stem Nut	1035
15	Handwheel	A197
16	Name Plate	SS
17	Lock Nut	CS

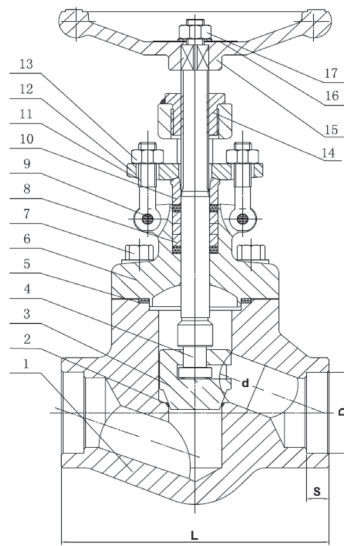

Size-NPT	DIMENSIONS			
	L	D	d	S
1/4"	3.11	0.56	0.28	0.38
3/8"	3.11	0.69	0.41	0.38
1/2"	3.11	0.86	0.41	0.38
3/4"	3.62	1.07	0.53	0.50
1"	4.37	1.33	0.71	0.50
1-1/4"	4.73	1.68	0.91	0.50
1-1/2"	5.98	1.92	1.14	0.50
2"	6.77	2.41	1.42	0.63

How to order 505F Series Globe Valves

Series	Material	Ends	Sizes	Trim
505F	C -Carbon Steel	T-Threaded	01 -1/4"*	8
		W -Socket Weld	02 -3/8"*	8
			03 -1/2"	8
			04 -3/4"	8
			05 -1"	8
			06 -1-1/4"	8
			07 -1-1/2"	8
			08 -2"	8

*Size 1/4" and 3/8" are Carbon Steel only

Sample Part #: 505FCT05-8

What do you need today?™

