

* AT FULL DIFFERENTIAL PRESSURE FOR CLEAN FLUIDS WITH DELRIN SEATS.

SIZE	A	øB	C	øD	E	F	G	H1	H2	J1	J2	K	L1	L2	øN1	N2	øN3	FNPT THREAD	PER SAE J1926 THREAD	WEIGHT (lbs)	Cv	TORQUE* (in-lbf)	BODY BOLT SIZE	BODY NUT SIZE
1/2"	0.27 (7)	0.74 (18)	0.51 (13)	0.44 (11)	3.06 (78)	5 (127)	1.7 (43)	0.81 (21)	2.00 (51)	0.22 (6)	0.37 (9)	M5-0.8	1.31 (33)	N/A	0.86 (22)	0.44 (11)	1.18 (30)	1/2"-14NPT	3/4"-16-8	2	8	55	5/16"-18 X 2"	5/16"-18
3/4"	0.27 (7)	0.86 (22)	0.40 (10)	0.56 (14)	3.34 (85)	5 (127)	1.9 (48)	0.97 (25)	2.38 (60)	0.22 (6)	0.37 (9)	M5-0.8	1.33 (34)	0.43 (11)	1.07 (27)	0.56 (14)	1.61 (41)	3/4"-14NPT	1-1/16"-12-12	3	12	190	5/16"-18 X 2.5"	5/16"-18
1"	0.31 (8)	1.05 (26)	0.83 (21)	0.82 (21)	4.25 (108)	6 (152)	2.4 (61)	1.25 (32)	2.26 (57)	0.30 (8)	0.43 (11)	M5-0.8	1.65 (42)	0.94 (24)	1.33 (34)	0.56 (14)	1.93 (49)	1"-11.5NPT	1-5/16"-12-16	5	32	290	3/8"-16 X 3"	3/8"-16

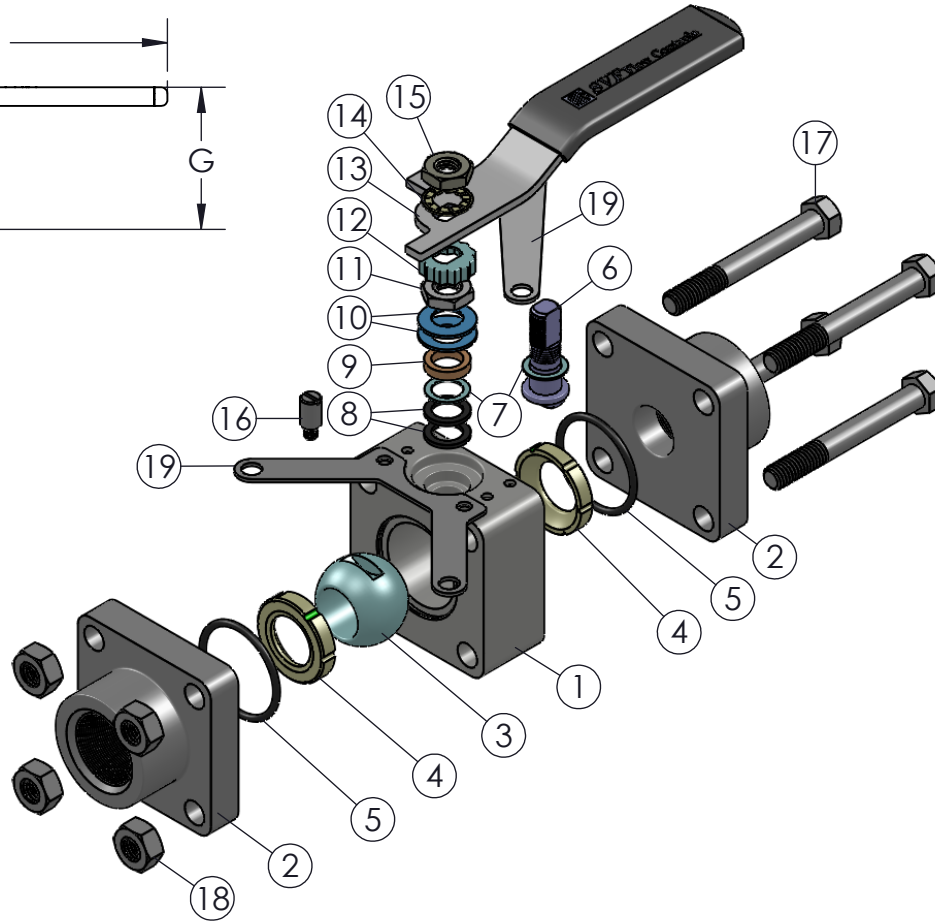
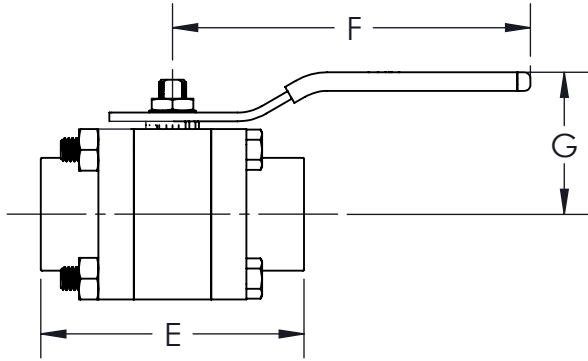

PRODUCT INFORMATION:
 1. END CONNECTIONS AVAILABLE IN: SCREWED END (FNPT), SOCKET WELD ENDS, SCREWED END PER SAE SPECIFICATION (J1926)(1/2" & 1" SIZE VALVES), SCREWED ENDS (FNPT) X SOCKET WELD END AND SCREWED END (SAE) X SOCKET WELD END (1/2" & 1" SIZE VALVES)
 2. SERVICES INCLUDE: HIGH CYCLE STEM KIT, VENT/RELIEF HOLE (UPSTREAM SIDE), ELECTROPOLISHED AND HIGH PRESSURE GAS SERVICE
 3. BALL IS VENTED ON THE STEM SLOT AREA
 4. ALL STAINLESS STEEL PASSIVATED
 5. MOUNTING KIT AVAILABLE FOR COMPLETE VALVE AUTOMATION

OPTIONS :
 1. LOCKING DEVICE
 2. ANTI-STATIC DEVICE

APPLICABLE STANDARDS:
 1. ASME B16.34: DESIGN
 2. ASME B16.11: FORGED STEEL FITTINGS, SOCKET-WELDING
 3. API 598: INSPECTION AND TESTING
 4. ANSI B1.20.1: NPT

TOPWORKS

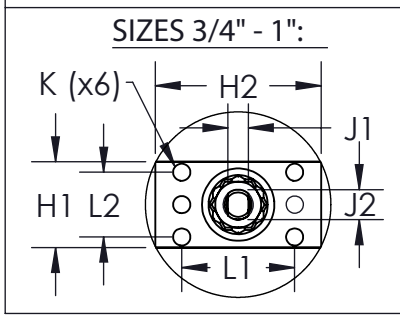
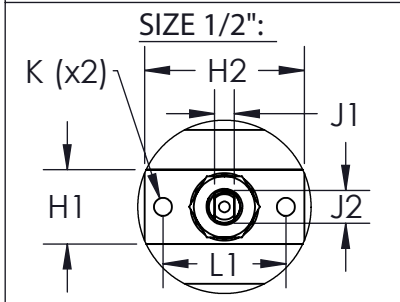
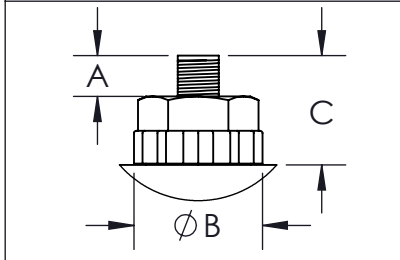

END CONFIGURATIONS:

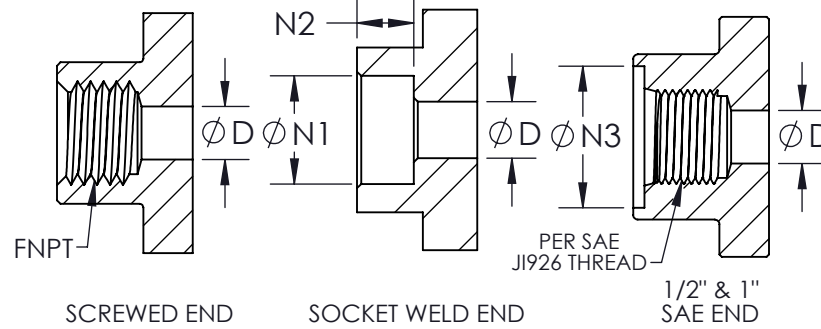

ITEM NO.	DESCRIPTION	MATERIALS	QTY.
1	BODY	A351-CF8M A216-WCB	1
2	END	A351-CF3M A216-WCB	2
3	BALL	A564-630	1
4	SEAT	DELRIN PEEK	2
5	BODY SEAL	BUNA N VITON EPDM	2
6	STEM	A564-630	1
7	STEM THRUST WASHER	PEEK	2
8	STEM SEAL	SUPRALON	2
9	GLAND FOLLOWER	304 STAINLESS STEEL	1
10	BELLEVILLE WASHER	17-7PH STAINLESS STEEL	2
11	JAM NUT	304 STAINLESS STEEL	1
12	LOCK TAB	304 STAINLESS STEEL	1
13	LEVER HANDLE	304 STAINLESS STEEL	1
14	SERRATED LOCK WASHER (1" ONLY)	304 STAINLESS STEEL	1
15	HANDLE NUT	304 STAINLESS STEEL	1
16	STOP PIN	304 STAINLESS STEEL	1
17	BODY BOLT	304 STAINLESS STEEL	4
18	BODY NUT	304 STAINLESS STEEL	4
19	LOCKING DEVICE (OPTIONAL)	304 STAINLESS STEEL	2

DRAWN BY E.P. DATE 04/04/2017
 CHECKED BY E.G. DATE 03/22/2018
 APPROVED BY J.S. DATE 03/22/2018
(FOR REF ONLY IF NOT APPROVED)

THE INFORMATION CONTAINED IN THIS DRAWING IS THE SOLE PROPERTY OF SVF FLOW CONTROLS, INC. ANY REPRODUCTION IN PART OR IN WHOLE WITHOUT THE WRITTEN CONSENT OF SVF FLOW CONTROLS, INC. IS PROHIBITED.
 PROJECTION THIRD ANGLE

SVF FLOW CONTROLS

DESCRIPTION: 1/2" - 1" P4 3-PIECE HIGH PRESSURE BALL VALVE

UNITS: INCH (MILLIMETERS) DATE: 03/22/2018 REV: C