

* AT FULL DIFFERENTIAL PRESSURE FOR CLEAN FLUIDS WITH TFM1 600 NON-CAVITY FILLED SEATS

SIZE	A	øB	C	øD	E1	E2	F	G	J1	J2	K	øL1	øL2	W	ISO 5211	WEIGHT (lbs)	Cv	TORQUE* (in-lbf)	BODY BOLT SIZE	BODY NUT SIZE
1/2"	0.24 (6)	1.0 (25)	0.64 (16)	0.37 (9)	5.50 (140)	3.50 (89)	5.0 (127)	2.22 (56)	0.22 (6)	0.37 (9)	M5-0.8	1.42 (36)	N/A	0.065 (1.7)	F03	2	8	60	M6 - 1.0 X 45	M6-1.0P
3/4"	0.24 (6)	1.0 (25)	0.64 (16)	0.62 (16)	6.00 (152)	4.00 (102)	5.0 (127)	2.28 (58)	0.22 (6)	0.37 (9)	M5-0.8	1.42 (36)	N/A	0.065 (1.7)	F03	2	29	60	M6-1.0 X 53	M6-1.0P
1"	0.36 (9)	1.2 (30)	0.78 (20)	0.87 (22)	6.50 (165)	4.50 (114)	6.0 (152)	2.56 (65)	0.30 (8)	0.43 (11)	M5-0.8	1.65 (42)	N/A	0.065 (1.7)	F04	4	66	100	M8 - 1.25 X 72	M8-1.25P
1-1/2"	0.50 (13)	1.4 (36)	1.27 (32)	1.37 (35)	7.50 (191)	5.50 (140)	7.0 (178)	3.09 (78)	0.34 (9)	0.56 (14)	M6-1.0	1.77 (45)	1.97 (50)	0.065 (1.7)	F05	8	192	200	M10-1.5 X 89	M10-1.5P
2"	0.46 (12)	1.4 (36)	1.23 (31)	1.87 (47)	8.00 (203)	6.25 (159)	7.0 (178)	3.45 (88)	0.34 (9)	0.56 (14)	M6-1.0	1.77 (45)	1.97 (50)	0.065 (1.7)	F05	13	434	250	M12-1.75 X 107	M12-1.75P

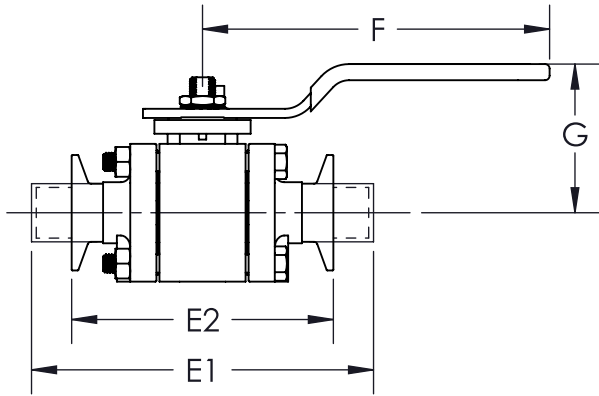

PRODUCT INFORMATION:
 1. END CONNECTIONS AVAILABLE IN: TRI-CLAMP, EXTENDED TUBE-OD, TRI-CLAMP X EXTENDED TUBE-OD AND EXTENDED TUBE-OD X TRI-CLAMP
 2. SERVICES INCLUDE: OXYGEN CLEANING, ELECTROPOLISH, HIGH CYCLE STEM KIT, AND VACUUM & SEARCHING GAS STEM KIT
 3. SULFUR CONTENT OF 0.005-0.017% FOR WELD ENDS
 4. CONTROLLED DELTA FERRITE CHEMISTRY
 5. INTERNAL SURFACE FINISH OF 20 Ra OR BETTER
 6. ALL STAINLESS STEEL PASSIVATED
 7. COMPLETE VALVE AUTOMATION

OPTIONS:
 1. OVAL HANDLE
 2. LOCKING DEVICE
 3. ISO STEM EXTENSION
 4. ANTI-STATIC DEVICE

APPLICABLE STANDARDS:
 1. ASME BPE: HYGIENIC
 2. ASME B16.34: DESIGN
 3. API 598: INSPECTION AND TESTING
 4. ISO 5211: MOUNTING
 5. CGA G-4.1: CLEANING FOR OXYGEN SERVICE
 6. FDA 21 CFR 177.1550 COMPLIANCE
 7. USP CLASS VI, SECTIONS 87 & 88: CONFIRMATION OF COMPLIANCE (TFM1 600/PTFE MATERIAL)

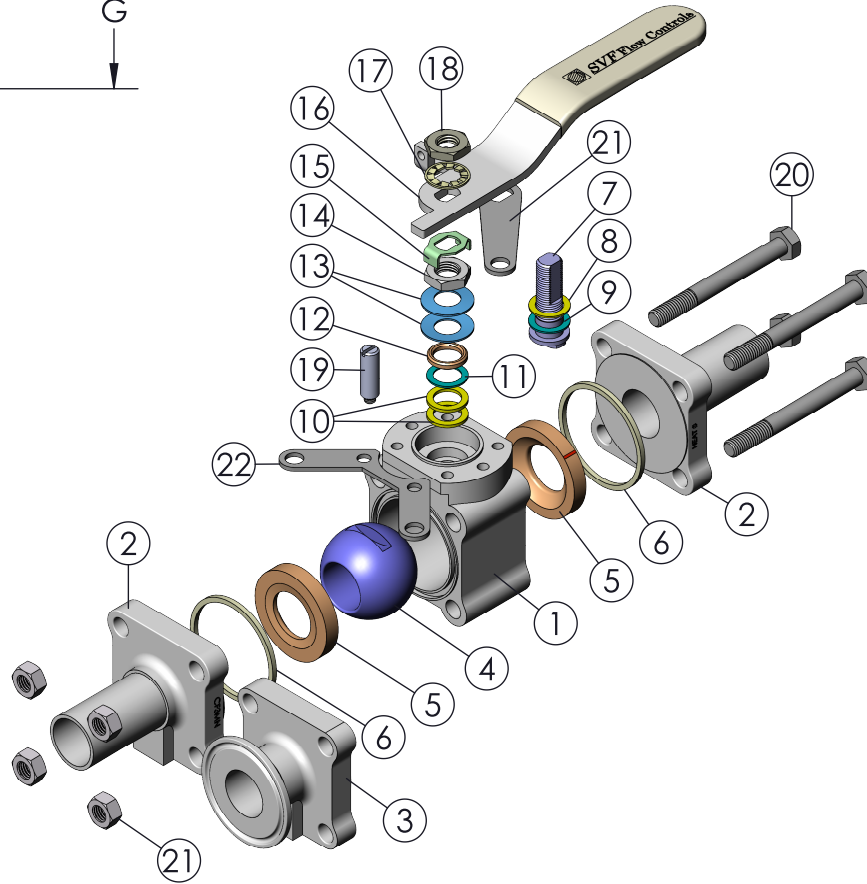

END CONFIGURATIONS:

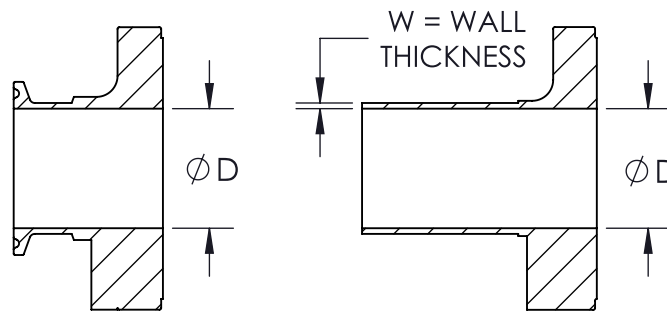

TRI-CLAMP END

EXTENDED TUBE-OD END

ITEM NO.	DESCRIPTION	MATERIALS	QTY.
1	BODY	A351-CF3MN A494 CW-12MW	1
2	ETO END	A351-CF3MN A494 CW-12MW	2
3	TRI-CLAMP END	A351-CF3MN A494 CW-12MW	2
4	BALL	A351-CF3MN A494 CW-12MW	1
5	SEAT	TFM1 600 CAVITY-FILLED TFM1 600	2
6	BODY SEAL	PTFE TFM1 600	2
7	STEM	A351-CF3MN A479-31 6L A494 CW-12MW	1
8	STEM THRUST WASHER	TFM1 600	1
9	STEM THRUST WASHER	VIRGIN PEEK	1
10	STEM SEAL	TFM1 600	2
11	STEM SEAL	VIRGIN PEEK	1
12	GLAND FOLLOWER	304 STAINLESS STEEL	1
13	BELLEVILLE WASHER	301 STAINLESS STEEL	2
14	JAM NUT	304 STAINLESS STEEL	1
15	LOCK TAB	304 STAINLESS STEEL	1
16	LEVER HANDLE	304 STAINLESS STEEL	1
17	SERRATED LOCK WASHER	304 STAINLESS STEEL	1
18	HANDLE NUT	304 STAINLESS STEEL	1
19	STOP PIN	304 STAINLESS STEEL	1
20	BODY BOLT	304 STAINLESS STEEL	4
21	BODY NUT	304 STAINLESS STEEL	4
22	LOCKING DEVICE (OPTIONAL)	304 STAINLESS STEEL	2

DRAWN BY E.P. DATE 04/04/2017
 CHECKED BY E.G. DATE 03/22/2018
 APPROVED BY J.S. DATE 03/22/2018
(FOR REF ONLY IF NOT APPROVED)

PROJECTION THIRD ANGLE:

DESCRIPTION: 1/2" - 2" SB7 3-PIECE CLEANFLOW HIGH PURITY BALL VALVE

UNITS: INCH (MILLIMETERS) DATE: 01/24/2019 REV: C



TOPWORKS

SIZES 1/2" - 1":

SIZES 1-1/2" - 2":



* AT FULL DIFFERENTIAL PRESSURE FOR CLEAN FLUIDS WITH TFM1600 NON-CAVITY FILLED SEATS

SIZE	A	øB	C	øD	E1	E2	F	G	J1	J2	K	øL1	øL2	W	ISO 5211	WEIGHT (lbs)	Cv	TORQUE* (in-lbf)	BODY BOLT SIZE	BODY NUT SIZE
2-1/2"	0.68 (17)	1.6 (41)	1.69 (43)	2.37 (60)	9.50 (241)	6.75 (171)	10.0 (254)	5.35 (136)	0.55 (14)	0.77 (20)	M8-1.25	2.76 (70)	3.03 (77)	0.065 (1.7)	F07	23	723	450	M16 - 2.0 X 123	M16-2.0P

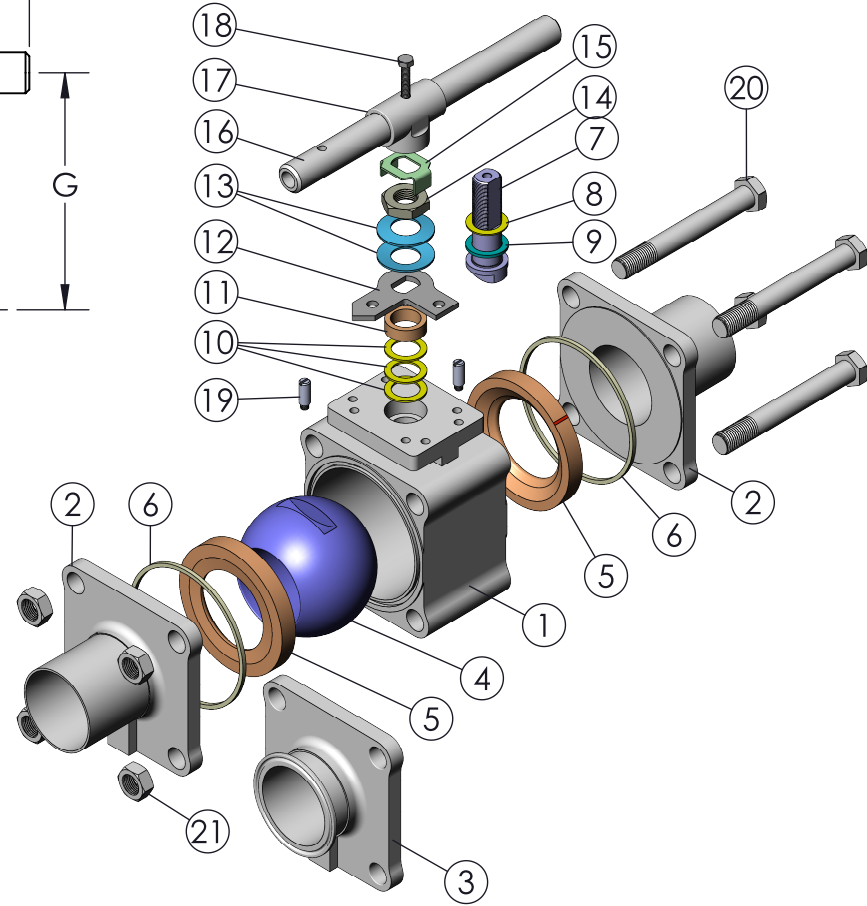
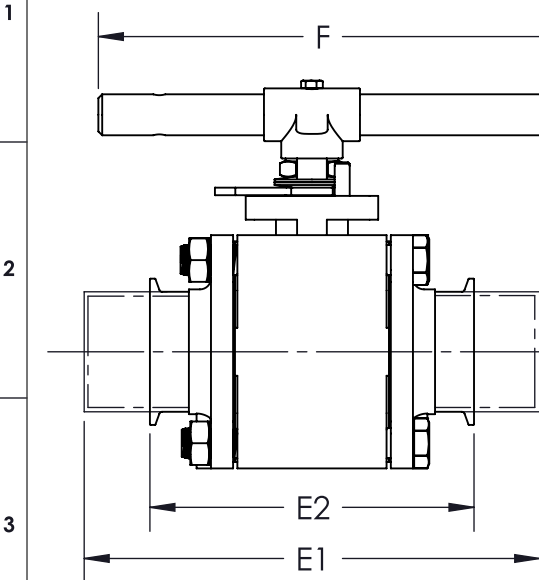

PRODUCT INFORMATION:
 1. END CONNECTIONS AVAILABLE IN: TRI-CLAMP, EXTENDED TUBE-OD, TRI-CLAMP X EXTENDED TUBE-OD AND EXTENDED TUBE-OD X TRI-CLAMP
 2. SERVICES INCLUDE: OXYGEN CLEANING, ELECTROPOLISH, HIGH CYCLE STEM KIT, AND VACUUM & SEARCHING GAS STEM KIT
 3. SULFUR CONTENT OF 0.005-0.017% FOR WELD ENDS
 4. CONTROLLED DELTA FERRITE CHEMISTRY
 5. INTERNAL SURFACE FINISH OF 20 Ra OR BETTER
 6. ALL STAINLESS STEEL PASSIVATED
 7. COMPLETE VALVE AUTOMATION

OPTIONS:
 1. OVAL HANDLE
 2. LOCKING DEVICE
 3. ISO STEM EXTENSION
 4. ANTI-STATIC DEVICE

APPLICABLE STANDARDS:
 1. ASME BPE: HYGIENIC
 2. ASME B16.34: DESIGN
 3. API 598: INSPECTION AND TESTING
 4. ISO 5211: MOUNTING
 5. CGA G-4.1: CLEANING FOR OXYGEN SERVICE
 6. FDA 21 CFR 177.1550 COMPLIANCE
 7. USP CLASS VI, SECTIONS 87 & 88: CONFIRMATION OF COMPLIANCE (TFM1600/PTFE MATERIAL)

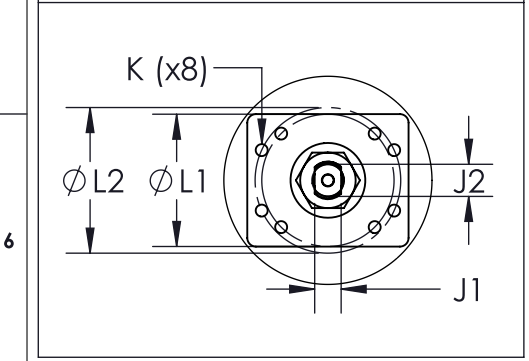
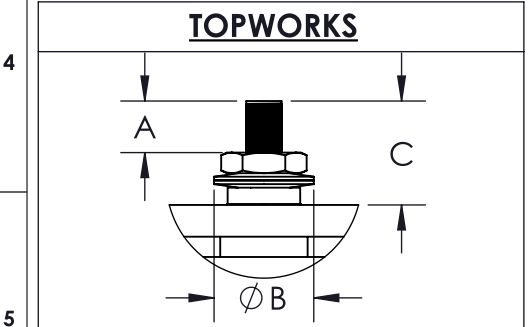

END CONFIGURATIONS:

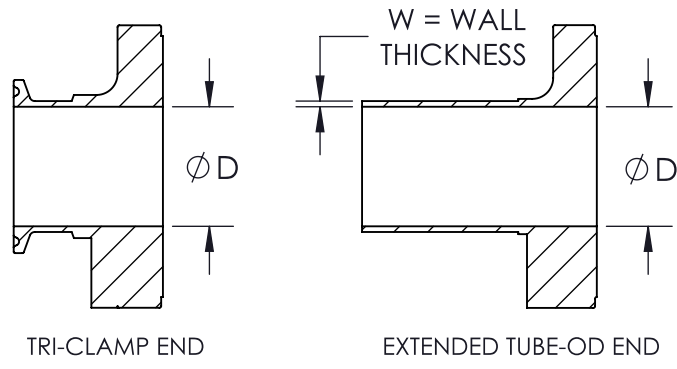

ITEM NO.	DESCRIPTION	MATERIALS	QTY.
1	BODY	A351-CF3MN A494 CW-12MW	1
2	ETO END	A351-CF3MN A494 CW-12MW	2
3	TRI-CLAMP END	A351-CF3MN A494 CW-12MW	2
4	BALL	A351-CF3MN A494 CW-12MW	1
5	SEAT	TFM1600 CAVITY-FILLED TFM1600	2
6	BODY SEAL	PTFE TFM1600	2
7	STEM	A351-CF3MN A479-316L A494 CW-12MW	1
8	STEM THRUST WASHER	TFM1600	1
9	STEM THRUST WASHER	VIRGIN PEEK	1
10	STEM SEAL	TFM1600	3
11	GLAND FOLLOWER	304 STAINLESS STEEL	1
12	STOP PLATE	304 STAINLESS STEEL	1
13	BELLEVILLE WASHER	301 STAINLESS STEEL	2
14	HANDLE NUT	304 STAINLESS STEEL	1
15	LOCK TAB	304 STAINLESS STEEL	1
16	WRENCH	304 STAINLESS STEEL	1
17	WRENCH BLOCK	304 STAINLESS STEEL	1
18	HANDLE BOLT	304 STAINLESS STEEL	1
19	STOP PIN	304 STAINLESS STEEL	2
20	BODY BOLT	304 STAINLESS STEEL	4
21	BODY NUT	304 STAINLESS STEEL	4

DRAWN BY E.P. DATE 04/04/2017
 CHECKED BY E.G. DATE 03/22/2018
 APPROVED BY J.S. DATE 03/22/2018
(FOR REF ONLY IF NOT APPROVED)

THE INFORMATION CONTAINED IN THIS DRAWING IS THE SOLE PROPERTY OF SVF FLOW CONTROLS, INC. ANY REPRODUCTION IN PART OR IN WHOLE WITHOUT THE WRITTEN CONSENT OF SVF FLOW CONTROLS, INC. IS PROHIBITED.
 PROJECTION THIRD ANGLE

SVF FLOW CONTROLS

DESCRIPTION:
 2-1/2" SB7 3-PIECE CLEANFLOW HIGH PURITY BALL VALVE

UNITS: INCH (MILLIMETERS) DATE: 01/24/2019 REV: C

* AT FULL DIFFERENTIAL PRESSURE FOR CLEAN FLUIDS WITH TFM1600 NON-CAVITY FILLED SEATS

SIZE	A	øB	C	øD	E1	E2	F	G	J1	J2	K1	K2	øL1	øL2	øL3	W	ISO 5211	WEIGHT (lbs)	Cv	TORQUE * (in-lbf)	BODY BOLT SIZE	BODY NUT SIZE
3"	0.78 (20)	1.90 (48)	1.85 (47)	2.87 (73)	10.50 (267)	7.00 (178)	14.00 (348)	6.55 (166)	0.75 (19)	N/A	M10-1.5	0.39 (10)	3.17 (81)	N/A	4.01 (102)	0.065 (1.7)	F10	31	1124	1300	M10-1.50x30	N/A
4"	0.78 (20)	1.90 (48)	1.85 (47)	3.83 (97)	12.50 (318)	8.50 (216)	22.00 (559)	7.14 (181)	0.75 (19)	N/A	M10-1.5	0.39 (10)	3.17 (81)	N/A	4.01 (102)	0.083 (2.1)	F10	46	2100	1400	M10-1.75x30	N/A

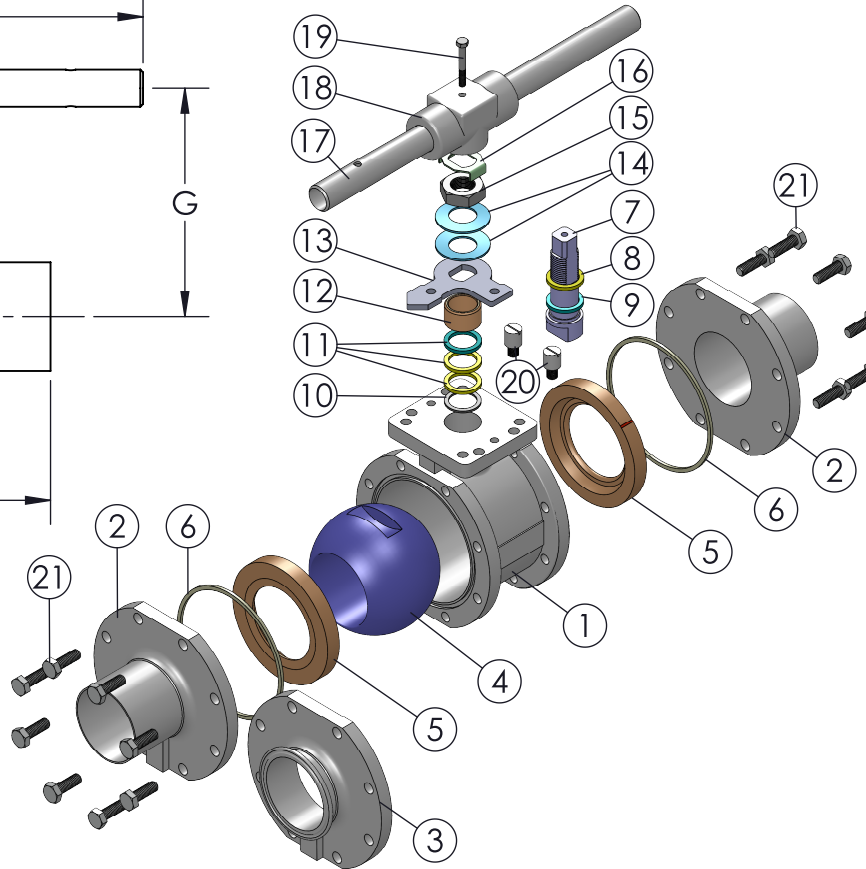
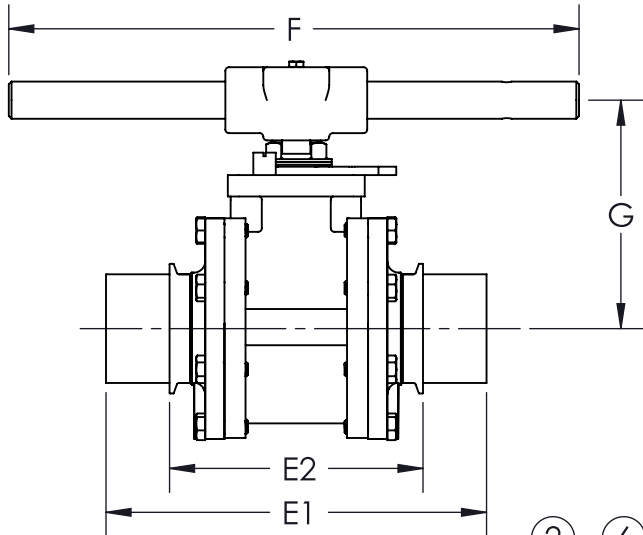

PRODUCT INFORMATION:
 1. END CONNECTIONS AVAILABLE IN: TRI-CLAMP, EXTENDED TUBE-OD, TRI-CLAMP X EXTENDED TUBE-OD AND EXTENDED TUBE-OD X TRI-CLAMP
 2. SERVICES INCLUDE: OXYGEN CLEANING, ELECTROPOLISH, HIGH CYCLE STEM KIT, AND VACUUM & SEARCHING GAS STEM KIT
 3. SULFUR CONTENT OF 0.005-0.017% FOR WELD ENDS
 4. CONTROLLED DELTA FERRITE CHEMISTRY
 5. INTERNAL SURFACE FINISH OF 20 Ra OR BETTER
 6. ALL STAINLESS STEEL PASSIVATED
 7. LOCKING DEVICE IS A STANDARD COMPONENT
 8. COMPLETE VALVE AUTOMATION

OPTIONS:
 1. ISO STEM EXTENSION
 2. ANTI-STATIC DEVICE

APPLICABLE STANDARDS:
 1. ASME BPE: HYGIENIC
 2. ASME B16.34: DESIGN
 3. API 598: INSPECTION AND TESTING
 4. ISO 5211: MOUNTING
 5. CGA G-4.1: CLEANING FOR OXYGEN SERVICE
 6. FDA 21 CFR 177.1550 COMPLIANCE
 7. USP CLASS VI, SECTIONS 87 & 88: CONFIRMATION OF COMPLIANCE (TFM1600/PTFE MATERIAL)

ITEM NO.	DESCRIPTION	MATERIALS	QTY.
1	BODY	A351-CF3MN A494 CW-12MW	1
2	ETO END	A351-CF3MN A494 CW-12MW	2
3	TRI-CLAMP END	A351-CF3MN A494 CW-12MW	2
4	BALL	A351-CF3MN A494 CW-12MW	1
5	SEAT	TFM1600 CAVITY-FILLED TFM1600	2
6	BODY SEAL	PTFE TFM1600	2
7	STEM	A351-CF3MN A479-316L A494 CW-12MW	1
8	STEM THRUST WASHER	TFM1600	1
9	STEM THRUST WASHER	VIRGIN PEEK	1
10	STEM LOCATION RING	316 STAINLESS STEEL	1
11	STEM SEAL	TFM1600	3
12	GLAND FOLLOWER	304 STAINLESS STEEL	1
13	STOP PLATE	304 STAINLESS STEEL	1
14	BELLEVILLE WASHER	301 STAINLESS STEEL	2
15	HANDLE NUT	304 STAINLESS STEEL	1
16	LOCK TAB	304 STAINLESS STEEL	1
17	WRENCH	304 STAINLESS STEEL	1
18	WRENCH BLOCK	304 STAINLESS STEEL	1
19	HANDLE BOLT	304 STAINLESS STEEL	1
20	STOP PIN	304 STAINLESS STEEL	2
21	BODY BOLT	304 STAINLESS STEEL	16

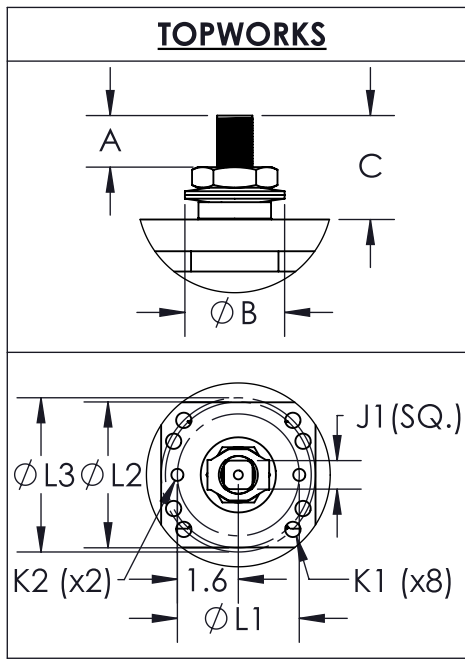

END CONFIGURATIONS:

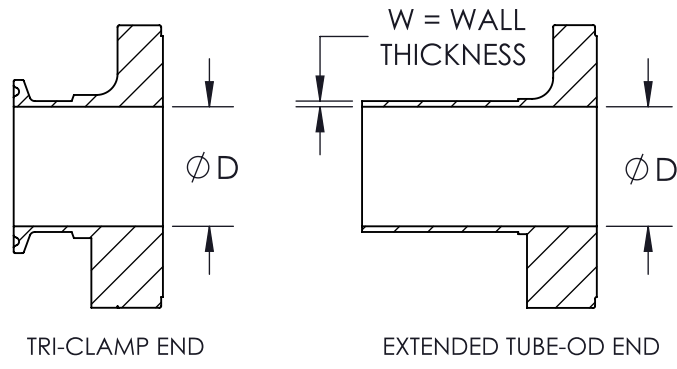

DRAWN BY E.P.
 CHECKED BY E.G.
 APPROVED BY J.S.
 DATE 04/10/2017
 DATE 03/22/2018
 DATE 03/22/2018

DESCRIPTION:
 3" & 4" SB7 3-PIECE CLEANFLOW HIGH PURITY BALL VALVE

UNITS: INCH (MILLIMETERS) DATE: 01/24/2019 REV: C



* AT FULL DIFFERENTIAL PRESSURE FOR CLEAN FLUIDS WITH TFM1600 NON-CAVITY FILLED SEATS

SIZE	A	ØB	C	ØD	E1	E2	F	G	J1	ØJ2	K	ØL1	ØL2	W	ISO 5211	WEIGHT (lbs)	Cv	TORQUE* (in-lbf)	BODY BOLT SIZE	BODY NUT SIZE
6"	1.50 (38)	3.15 (80)	3.26 (83)	5.78 (147)	16.0 (406)	17.0 (432)	26.0 (660)	12.0 (305)	1.02 (26)	1.61 (41)	1/2"-13UNC	4.17 (106)	4.92 (125)	0.109 (2.8)	F12	196	4700	4160	5/8"-11 x 2"	N/A

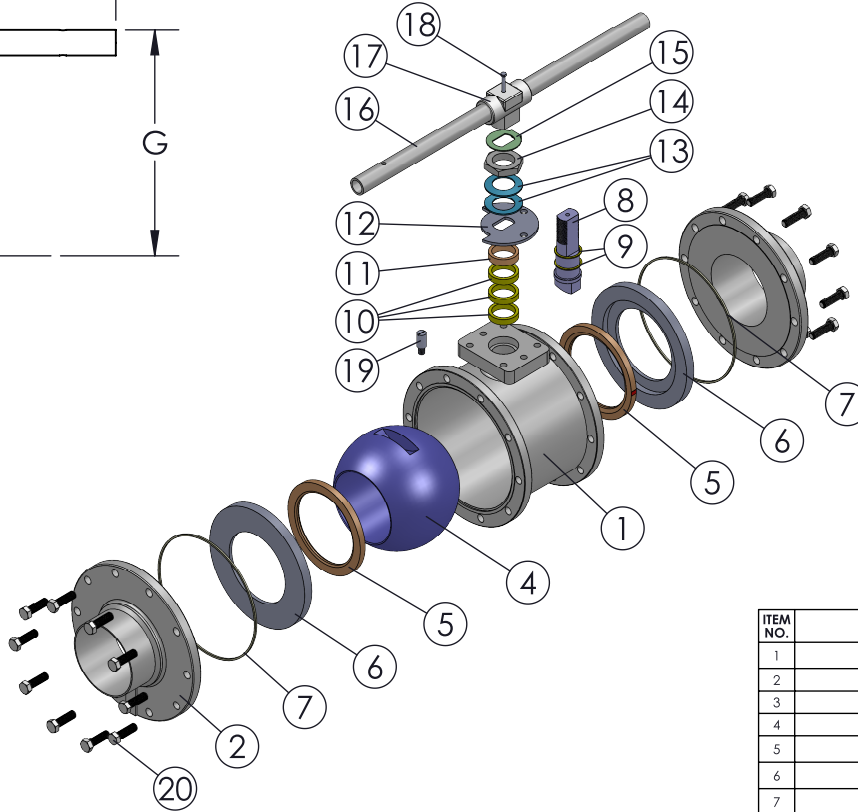
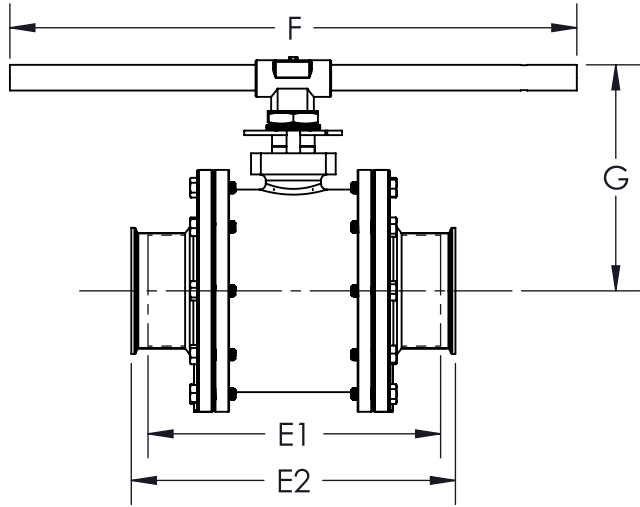

PRODUCT INFORMATION:

1. END CONNECTIONS AVAILABLE IN: TRI-CLAMP, EXTENDED TUBE-OD, TRI-CLAMP X EXTENDED TUBE-OD AND EXTENDED TUBE-OD X TRI-CLAMP
2. SERVICES INCLUDE: OXYGEN CLEANING AND ELECTROPOLISH
3. SULFUR CONTENT OF 0.005-0.017% FOR WELD ENDS
4. CONTROLLED DELTA FERRITE CHEMISTRY
5. INTERNAL SURFACE FINISH OF 20 Ra OR BETTER
6. ALL STAINLESS STEEL PASSIVATED
7. LOCKING DEVICE IS A STANDARD COMPONENT
8. COMPLETE VALVE AUTOMATION

OPTIONS:

1. ISO STEM EXTENSION
2. ANTI-STATIC DEVICE

APPLICABLE STANDARDS:

1. ASME BPE: HYGIENIC
2. ASME B16.34: DESIGN
3. API 598: INSPECTION AND TESTING
4. ISO 5211: MOUNTING
5. CGA G-4.1: CLEANING FOR OXYGEN SERVICE
6. FDA 21 CFR 177.1550 COMPLIANCE
7. USP CLASS VI, SECTIONS 87 & 88: CONFIRMATION OF COMPLIANCE (TFM1600/PDFF MATERIAL)

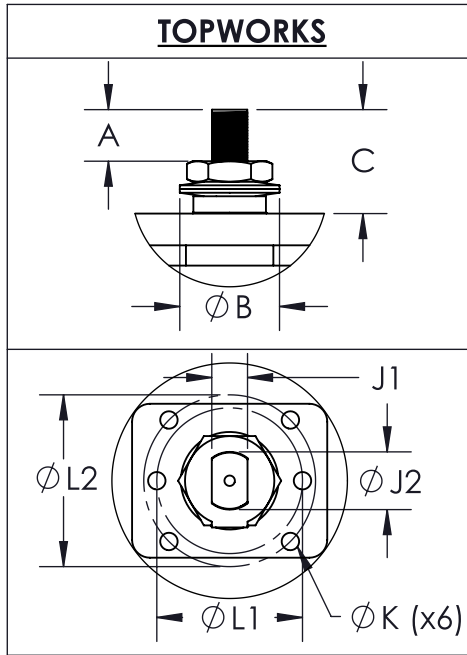

END CONFIGURATIONS:

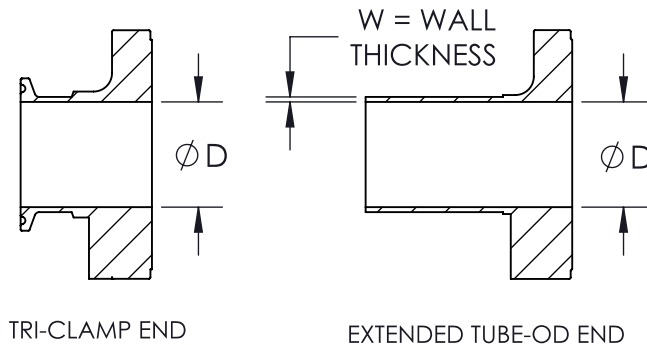

ITEM NO.	DESCRIPTION	MATERIALS	QTY.
1	BODY	A351-CF3MN A494 CW-12MW	1
2	ETO END	A351-CF3MN A494 CW-12MW	2
3	TRI-CLAMP END	A351-CF3MN A494 CW-12MW	2
4	BALL	A351-CF3MN A494 CW-12MW	1
5	SEAT	TFM1600 CAVITY-FILLED TFM1600	2
6	SEAT RETAINER	316 STAINLESS STEEL	2
7	BODY SEAL	TFM1600	2
8	STEM	A351-CF3MN A479-316L A494 CW-12MW	1
9	STEM THRUST WASHER	TFM1600	2
10	STEM SEAL	TFM1600	3
11	GLAND FOLLOWER	304 STAINLESS STEEL	1
12	STOP PLATE	304 STAINLESS STEEL	1
13	BELLEVILLE WASHER	301 STAINLESS STEEL	2
14	HANDLE NUT	304 STAINLESS STEEL	1
15	LOCK TAB	304 STAINLESS STEEL	1
16	WRENCH	304 STAINLESS STEEL	1
17	WRENCH BLOCK	304 STAINLESS STEEL	1
18	HANDLE BOLT	304 STAINLESS STEEL	1
19	STOP PIN	304 STAINLESS STEEL	1
20	BODY BOLT	304 STAINLESS STEEL	20

DRAWN BY C.L.	DATE 06/20/2017
CHECKED BY E.P.	DATE 03/22/2018
APPROVED BY J.S. <small>(FOR REF ONLY IF NOT APPROVED)</small>	DATE 03/22/2018

THE INFORMATION CONTAINED IN THIS DRAWING IS THE SOLE PROPERTY OF SVF FLOW CONTROLS, INC. ANY REPRODUCTION IN PART OR IN WHOLE WITHOUT THE WRITTEN CONSENT OF SVF FLOW CONTROLS, INC. IS PROHIBITED.

PROJECTION THIRD ANGLE:

OSVF FLOW CONTROLS

DESCRIPTION:
6" SB7 3-PIECE CLEANFLOW HIGH PURITY BALL VALVE

UNITS: INCH (MILLIMETERS) DATE: 01/24/2019 REV: C