

Series 520F-8 Trim 8 Swing Check Valve

Sizes 1/2" ~ 2"



SERIES 520F DESIGN FEATURES

- ✓ Trim 8 Forged Carbon Steel
- ✓ Class 800
- ✓ Reduced Port
- ✓ Maximum Pressure 1975 psi @ 100°F
- ✓ Maximum Temperature 850°F @ 850 psi
- ✓ Bolted bonnet
- ✓ API 602 compliant
- ✓ Standard NACE MRO175



MATERIALS OF CONSTRUCTION

No.	Part	Material
1	Body	A105
2	Seat	A276 410
3	Disc	A276 420+STL
4	Nut	A194 8
5	Arm	A182 F304
6	Bolt	ASTM A193 B8
7	Gasket	SS304+Graphite
8	Bonnet	ASTM A105
9	Bolt	ASTM A193 B7

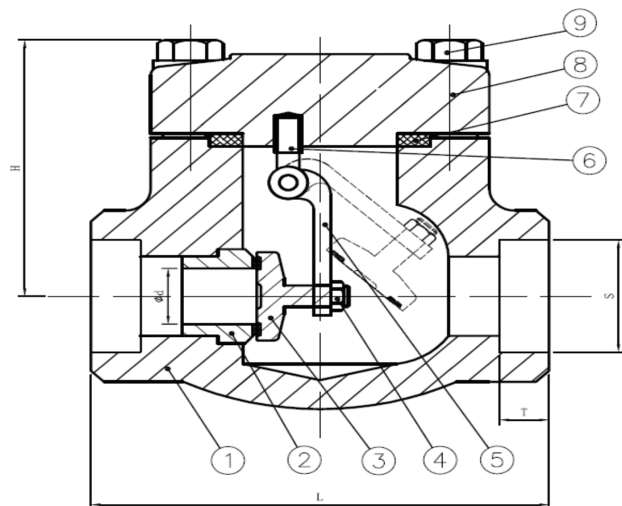

DIMENSIONS

Size	d	L	H	S*	T*
1/2"	0.41	3.11	2.44	0.86	0.39
3/4"	0.51	3.62	2.48	1.07	0.51
1"	0.71	4.37	2.76	1.34	0.51
1-1/4"	0.95	4.73	3.35	1.68	0.51
1-1/2"	1.14	4.73	3.62	1.92	0.51
2"	1.44	5.52	3.98	2.41	0.63

*Socket weld only

How to order 520F Series Check Valves

Series	Material	Ends	Sizes	Trim
520F	C -Carbon Steel	T-Threaded	03 -1/2"	8
		W-Socket Weld	04 -3/4"	8
			05 -1"	8
			06 -1-1/4"	8
			07 -1-1/2"	8
			08 -2"	8

Sample Part #: 520FCT05-8

What do you need today?™

