

# Series 522F - 8 Check Valve

Sizes 1/4" ~ 2"  
Trim 8



## SERIES 522F DESIGN FEATURES

- ✓ Trim 8 Forged Carbon Steel
- ✓ Class 800
- ✓ Maximum Pressure 1975 psi
- ✓ Maximum Temperature 850°F
- ✓ Bolted bonnet
- ✓ API 602 compliant
- ✓ Standard NACE MRO175



## MATERIALS OF CONSTRUCTION

No.	Part	Material
1	Body	A105
2	Seat	STL
3	Disc	13Cr
4	Gasket	SS304 Flexible Graphite
5	Cover	A105
6	Name Plate	AL
7	Spring	SS304
8	Bolt	B7

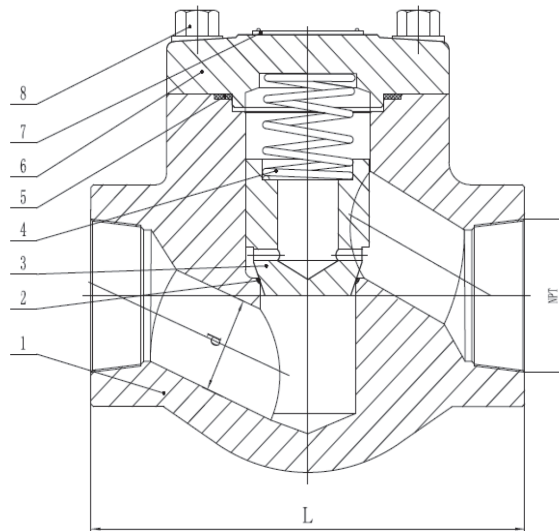

## DIMENSIONS

Size-NPT	L	d
1/4"	3.11	0.24
3/8"	3.11	0.32
1/2"	3.11	0.39
3/4"	3.62	0.51
1"	4.37	0.69
1-1/4"	4.73	0.91
1-1/2"	5.98	1.10
2"	6.77	1.38

## How to order 522F Series Check Valves

Series	Material	Ends	Sizes	Trim
522F	C -Carbon Steel	T-Threaded	01 -1/4"*	8
		W -Socket Weld	02 -3/8"*	8
			03 -1/2"	8
			04 -3/4"	8
			05 -1"	8
			06 -1-1/4"	8
			07 -1-1/2"	8
			08 -2"	8

\*Size 1/4" and 3/8" are Carbon Steel only  
Sample Part #: 522FCT05-8

*What do you need today?*™

