

A B C D E F G

\* AT FULL DIFFERENTIAL PRESSURE FOR CLEAN FLUIDS WITH TFM1600 SEATS

SIZE	A	øD	E1	E2	F	G1	G2	□J1	øK1	øK2	øL1	øL2	øN1	N2	øN3	øM	NPT THREAD	ISO 5211	WEIGHT (lbs)	Cv	TORQUE* (in-lbf)
1/4"	0.31 (8)	0.43 (11)	2.56 (65)	2.95 (75)	4.41 (112)	3.07 (78)	1.50 (38)	0.35 (9)	-	M5-0.8	-	1.65 (42)	0.55 (14)	0.39 (10)	0.30 (7.6)	0.54 (13.8)	1/4"-18NPT	F04-F05	1.7	12	62
3/8"	0.31 (8)	0.43 (11)	2.56 (65)	2.95 (75)	4.41 (112)	3.07 (78)	1.50 (38)	0.35 (9)	-	M5-0.8	-	1.65 (42)	0.71 (18)	0.39 (10)	0.42 (10.7)	0.68 (17.3)	3/8"-18NPT	F04-F05	1.7	14	62
1/2"	0.31 (8)	0.55 (14)	2.95 (75)	2.95 (75)	4.41 (112)	3.07 (78)	1.50 (38)	0.35 (9)	-	M5-0.8	-	1.65 (42)	0.87 (22)	0.51 (13)	0.55 (14.0)	0.84 (21.3)	1/2"-14NPT	F04-F05	1.9	42	97
3/4"	0.43 (11)	0.83 (21)	3.15 (80)	3.54 (90)	7.32 (186)	3.50 (89)	1.97 (50)	0.43 (11)	0.24 (6)	0.28 (7)	1.65 (42)	1.97 (50)	1.06 (27)	0.59 (15)	0.74 (18.8)	1.05 (26.7)	3/4"-14NPT	F04-F05	2.9	73	150
1"	0.43 (11)	0.98 (25)	3.54 (90)	3.94 (100)	7.32 (186)	3.90 (99)	2.36 (60)	0.43 (11)	0.24 (6)	0.28 (7)	1.65 (42)	1.97 (50)	1.34 (34)	0.59 (15)	0.96 (24.4)	1.31 (33.4)	1"-11.5NPT	F04-F05	4.2	113	221
1-1/4"	0.55 (14)	1.24 (32)	4.33 (110)	4.33 (110)	7.80 (198)	4.72 (120)	2.95 (75)	0.55 (14)	0.28 (7)	0.35 (9)	1.97 (50)	2.76 (70)	1.69 (43)	0.59 (15)	1.28 (32.5)	1.66 (42.2)	1-1/4"-11.5NPT	F05-F07	6.2	183	285
1-1/2"	0.55 (14)	1.46 (37)	4.72 (120)	4.92 (125)	7.80 (198)	4.88 (124)	3.11 (79)	0.55 (14)	0.28 (7)	0.35 (9)	1.97 (50)	2.76 (70)	1.93 (49)	0.63 (16)	1.50 (38.1)	1.90 (48.3)	1-1/2"-11.5NPT	F05-F07	9.7	273	443
2"	0.55 (14)	1.97 (50)	5.51 (140)	5.91 (150)	7.80 (198)	5.55 (141)	3.78 (96)	0.55 (14)	0.28 (7)	0.35 (9)	1.97 (50)	2.76 (70)	2.40 (61)	0.67 (17)	1.94 (49.3)	2.37 (60.3)	2"-11.5NPT	F05-F07	14.8	485	575

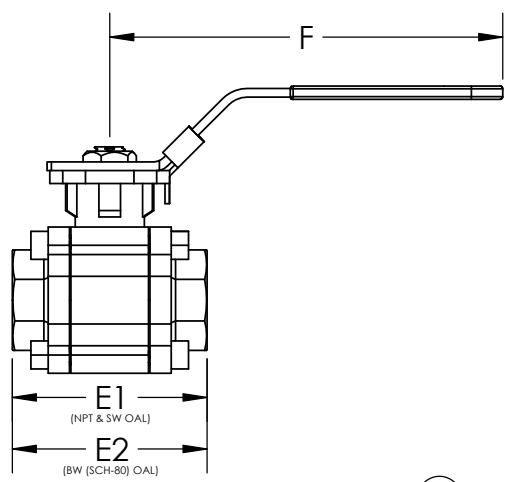
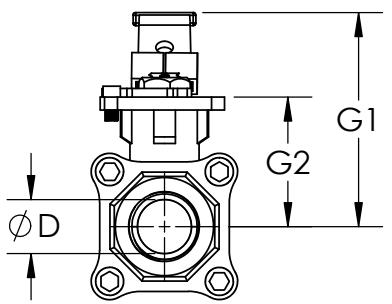

**TOPWORKS**

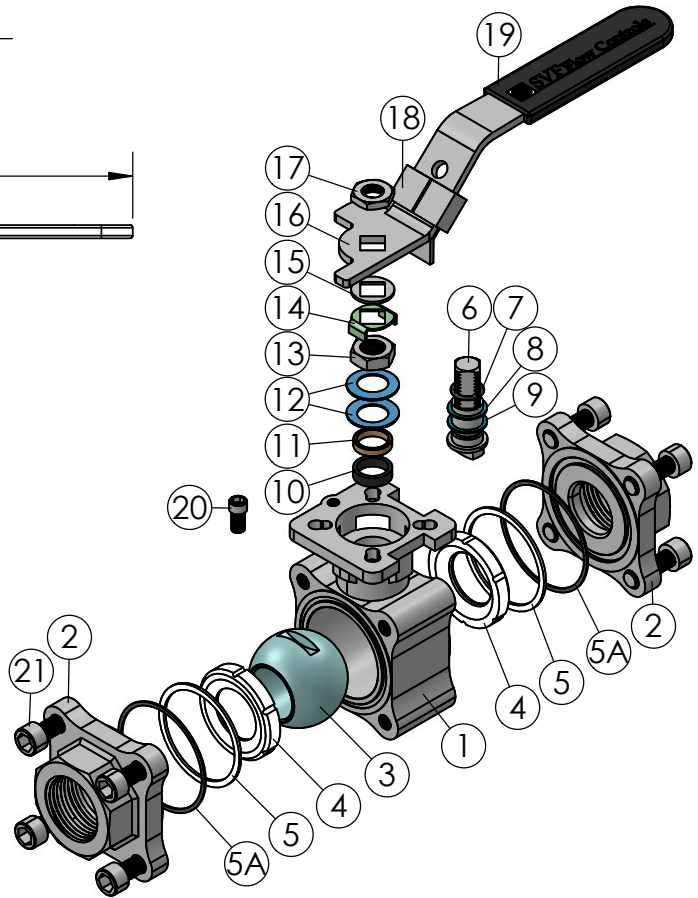
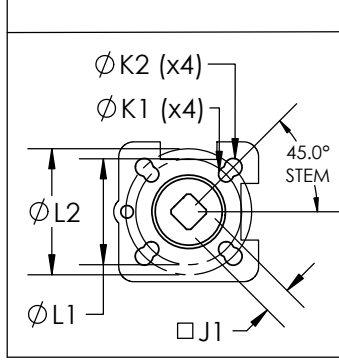
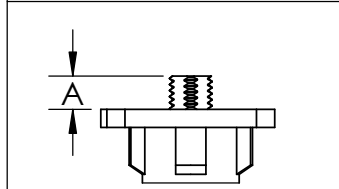

**END CONFIGURATIONS:**

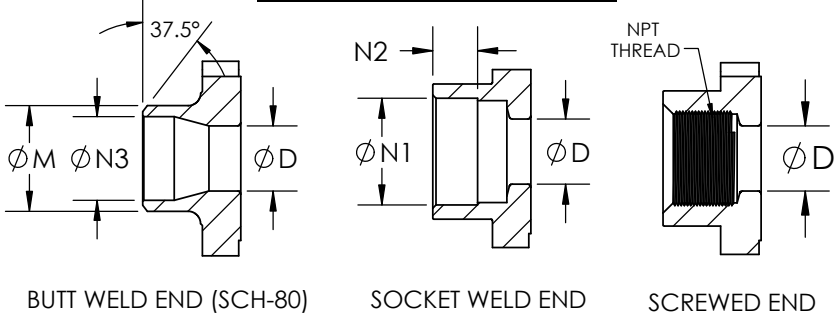

**PRODUCT INFORMATION:**

1. END CONNECTIONS AVAILABLE IN: SCREWED (FNPT), SOCKET WELD
2. SERVICES INCLUDE: OXYGEN CLEANING, DEGREASING AND VENT/RELIEF HOLE
3. BALL IS VENTED ON THE STEM SLOT AREA
4. ANTI-STATIC DEVICE
5. ALL STAINLESS STEEL PASSIVATED
6. MANGANESE PHOSPHATE COATING ON WCB CARBON STEEL
7. COMPLETE VALVE AUTOMATION

**APPLICABLE STANDARDS:**

1. NACE MR0175
2. ASME B16.34: DESIGN
3. API 598: INSPECTION AND TESTING
4. API 607: FIRE SAFE
5. API 608: METAL BALL VALVES - FLANGED, THREADED, AND WELDING ENDS
6. ISO 5211: MOUNTING
7. ANSI B1.20.1: NPT
8. ANSI B16.11: FORGED STEEL FITTINGS, SOCKET-WELDING
9. CGA G-4.1: CLEANING FOR OXYGEN SERVICE
10. USP CLASS VI: CONFIRMATION OF COMPLIANCE (TFM1600 MATERIAL)

ITEM NO.	DESCRIPTION	MATERIALS	QTY.
1	BODY	A351-CF8M A216-WCB	1
2	END	A351-CF8M A216-WCB	2
3	BALL	A351-CF8M	1
4	SEAT	TFM1600	2
5	BODY SEAL	PTFE	2
5A	BODY SEAL	GRAFOIL	2
6	STEM	A479-316	1
7	STEM O-RING	VITON	1
8	STEM THRUST WASHER	GRAFOIL	1
9	STEM THRUST WASHER	PTFE	1
10	STEM SEAL	GRAFOIL	1
11	GLAND FOLLOWER	304 STAINLESS STEEL	1
12	BELLEVILLE WASHER	301 STAINLESS STEEL	2
13	JAM NUT	304 STAINLESS STEEL	1
14	LOCK TAB	304 STAINLESS STEEL	1
15	HANDLE WASHER	304 STAINLESS STEEL	1
16	LEVER HANDLE	304 STAINLESS STEEL	1
17	HANDLE NUT	304 STAINLESS STEEL	1
18	LOCKING DEVICE	304 STAINLESS STEEL	1
19	HANDLE SLEEVE	PLASTIC	1
20	STOP PIN	304 STAINLESS STEEL	1
21	BODY BOLT	A193 B8 A193 B7	8

DRAWN BY C.L. DATE 10/23/2019  
 CHECKED BY C.L. DATE 05/18/2021  
 APPROVED BY J.S. DATE 05/18/2021  
(FOR REF ONLY IF NOT APPROVED)

**SVF FLOW CONTROLS**  
 5595 Fresca Drive • La Palma, CA 90623 • 1.800.783.7836  
 www.SVF.net • Sales@SVF.net

DESCRIPTION:  
 1/4" - 2" FB9 3-PIECE BALL VALVE, FULL PORT

UNITS: INCH (MILLIMETERS) DATE: 05/18/2021 REV: F