

50SSTH S.S. Threaded Globe Valve • Spec Sheet



FEATURES & BENEFITS

- W.P. 200WOG
- W.T. -4°F - 392°F
- 316 Stainless Steel Body
- Investment Casting
- Rising Stem
- Integral Seat
- Thread Type: NPT
- Sizes 1/2" - 2"

MATERIAL SPECIFICATIONS

No.	Part	Material
1	Body	Stainless Steel 316
2	Disc	Stainless Steel 316
3	Bonnet	Stainless Steel 316
4	Gasket	PTFE
5	Whorl Gasket	Stainless Steel 304
6	Packing	PTFE
7	Gland	Stainless Steel 304
8	Cap Nut	Stainless Steel 316
9	Stem	Stainless Steel 316
10	Handle	Aluminum
11	Name Plate	Aluminum
12	Nut	Stainless Steel 304

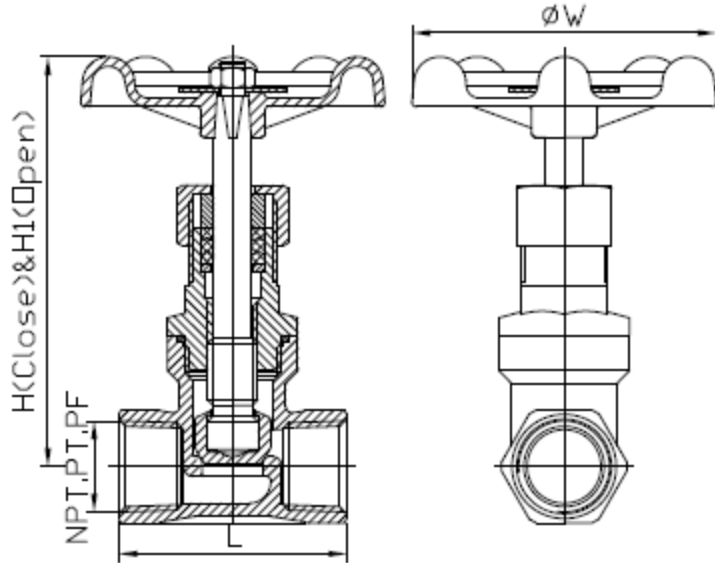

DIMENSIONS

Part #	Size	L	H (Close)	H1 (Open)	W	Weight (lb)
50SSTH03	1/2"	2.05	3.74	4.11	4.18	0.75
50SSTH04	3/4"	2.60	4.01	4.48	4.49	0.99
50SSTH05	1"	2.99	4.38	5.00	5.00	1.46
50SSTH06	1-1/4"	3.39	5.13	6.18	5.91	2.16
50SSTH07	1-1/2"	3.70	5.26	5.82	6.07	2.80
50SSTH08	2"	4.65	5.94	6.75	6.70	4.48

