

# Series 505F Globe Valve

Sizes 1/4" ~ 2"



## SERIES 505F DESIGN FEATURES

- ✓ Forged Carbon or Stainless Steel
- ✓ Class 800
- ✓ Maximum Pressure 1975 psi
- ✓ Maximum Temperature 850°F
- ✓ Bolted bonnet
- ✓ API 602 compliant
- ✓ Standard NACE MRO175



## MATERIALS OF CONSTRUCTION

No.	Part	Material Stainless
1	Body	F316L
2	Seat	INT
3	Disc	F316L
4	Stem	F316L
5	Gasket	SS16 Flexible Graphite
6	Bonnet	F316L
7	Bolt	B8M
8	Packing	Graphite
9	Pin	304
10	Pkg Press Sleeve	F316L
11	Live Bolt	B8M
12	Pkg Press Plate	F316L
13	Hex Nut	8M
14	Stem Nut	1035
15	Handwheel	A197
16	Name Plate	SS
17	Lock Nut	CS

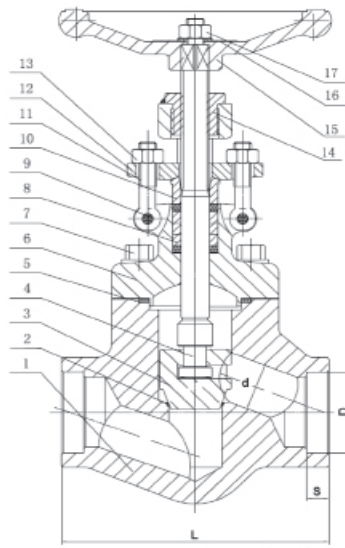

DIMENSIONS				
Size-NPT	L	D	d	S
1/4"	3.11	0.56	0.28	0.38
3/8"	3.11	0.69	0.41	0.38
1/2"	3.11	0.86	0.41	0.38
3/4"	3.62	1.07	0.53	0.50
1"	4.37	1.33	0.71	0.50
1-1/4"	4.73	1.68	0.91	0.50
1-1/2"	4.73	1.92	1.14	0.50
2"	5.52	2.41	1.42	0.63

### How to order 505F Series Globe Valves

Series	Material	Ends	Sizes
505F	SS-Stainless Steel	T-Threaded	01-1/4"*
		W-Socket Weld	02-3/8"*
			03-1/2"
			04-3/4"
			05-1"
			06-1-1/4"
			07-1-1/2"
			08-2"

Sample Part #: 505SST05

