

*AT FULL DIFFERENTIAL PRESSURE FOR CLEAN FLUIDS WITH PTFE SEATS

SIZE	A	øD	E1	E2	E3	F	G1	G2	J1 (SQ.)	øK1	øK2	øL1	øL2	NPT THREAD	ISO 5211	WEIGHT (lbs)	Cv	TORQUE* (in-lbf)
1/2"	0.35 (9)	0.63 (16)	3.39 (86)	2.83 (72)	1.73 (44)	4.84 (123)	3.00 (76)	1.73 (44)	0.35 (9)	0.24 (6)	0.24 (6)	1.42 (36)	1.65 (42)	1/2"-14NPT	F03-F04	3	14	118
3/4"	0.43 (11)	0.79 (20)	3.90 (99)	3.15 (80)	1.89 (48)	6.02 (153)	3.43 (87)	2.13 (54)	0.43 (11)	0.24 (6)	0.28 (7)	1.65 (42)	1.97 (50)	3/4"-14NPT	F04-F05	4	18	180
1"	0.43 (11)	0.98 (25)	4.61 (117)	3.70 (94)	2.24 (57)	6.02 (153)	3.66 (93)	2.32 (59)	0.43 (11)	0.24 (6)	0.28 (7)	1.65 (42)	1.97 (50)	1"-11.5NPT	F04-F05	5	43	217
1-1/2"	0.55 (14)	1.50 (38)	5.83 (148)	4.92 (125)	2.91 (74)	7.20 (183)	4.69 (119)	3.31 (84)	0.55 (14)	0.28 (7)	0.35 (9)	1.97 (50)	2.76 (70)	1-1/2"-11.5NPT	F05-F07	13	90	384
2"	0.55 (14)	1.97 (50)	6.30 (160)	5.12 (130)	3.35 (85)	9.69 (246)	4.92 (125)	3.62 (92)	0.55 (14)	0.28 (7)	0.35 (9)	1.97 (50)	2.76 (70)	2"-11.5NPT	F05-F07	20	160	526

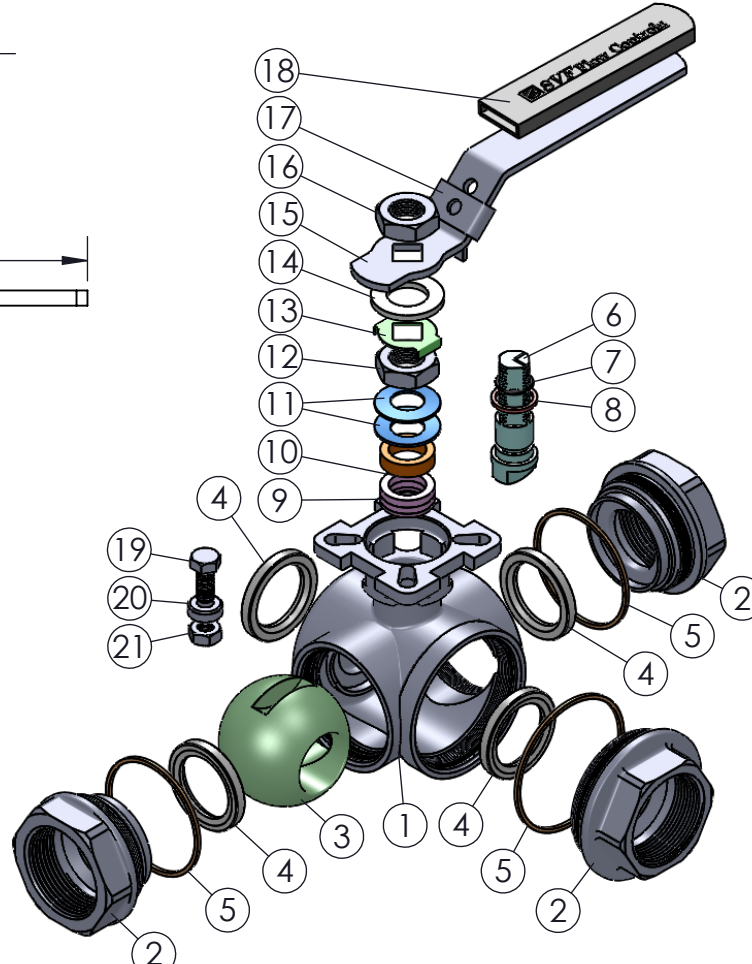
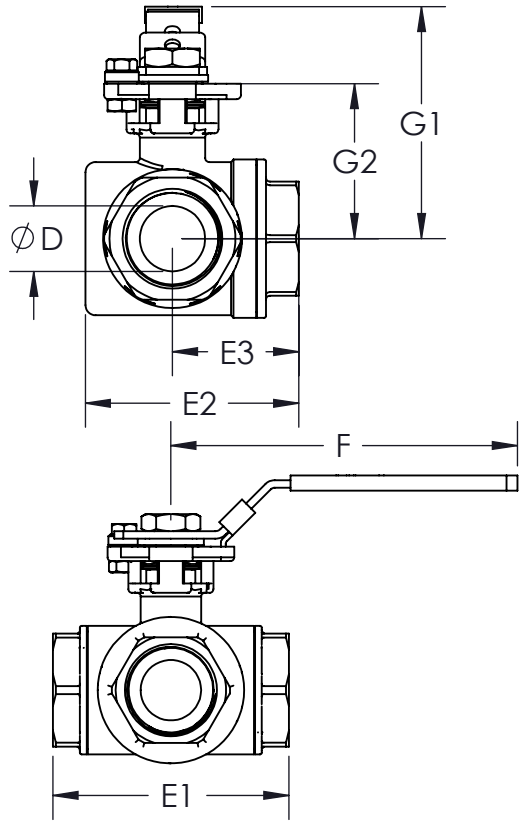

PRODUCT INFORMATION:

1. END CONNECTIONS AVAILABLE IN: SCREWED ENDS (FNPT)
2. BLOW-OUT PROOF STEM/FULL PORT
3. BALL IS VENTED ON THE STEM SLOT AREA
4. LIVE- LOADED STEM SEAL
5. ANTI-STATIC DEVICE
6. COMPLETE VALVE AUTOMATION

APPLICABLE STANDARDS:

1. ASME B16.34: DESIGN
2. API 598: INSPECTION AND TESTING
3. ISO 5211: MOUNTING
4. ISO 228: CLASS A
5. ANSI B1.20.1: NPT
6. CGA G-4.1: CLEANING FOR OXYGEN SERVICE
7. USP CLASS VI: CONFIRMATION OF COMPLIANCE (PTFE MATERIAL)

FLOW PATTERN:

PORT TYPE	1	2	3	4
L	1/3 2/3	1/3 2/3	1/3 2/3	1/3 2/3

ITEM NO.	DESCRIPTION	MATERIALS	QTY.
1	BODY	A351-CF8M	1
2	END	A351-CF8M	3
3	BALL	A351-CF8M	1
4	SEAT	PTFE	4
5	BODY SEAL	PTFE	3
6	STEM	A276-316	1
7	STEM O-RING	VITON	1
8	STEM THRUST WASHER	TFM4215	1
9	STEM SEAL	PTFE	3
10	SPACER	304 STAINLESS STEEL	1
11	BELLEVILLE WASHER	301 STAINLESS STEEL	2
12	STEM NUT	304 STAINLESS STEEL	1
13	LOCK TAB	304 STAINLESS STEEL	1
14	HANDLE WASHER	304 STAINLESS STEEL	1
15	LEVER HANDLE	304 STAINLESS STEEL	1
16	STEM NUT	304 STAINLESS STEEL	1
17	LOCKING DEVICE	304 STAINLESS STEEL	1
18	HANDLE SLEEVE	PLASTIC	1
19	STOP PIN BOLT	304 STAINLESS STEEL	1
20	STOP PIN	304 STAINLESS STEEL	1
21	STOP PIN NUT	304 STAINLESS STEEL	1

END CONFIGURATION:

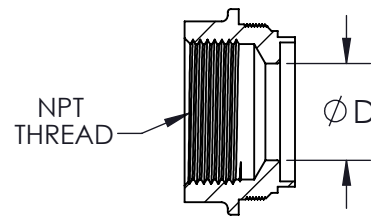

SCREWED END

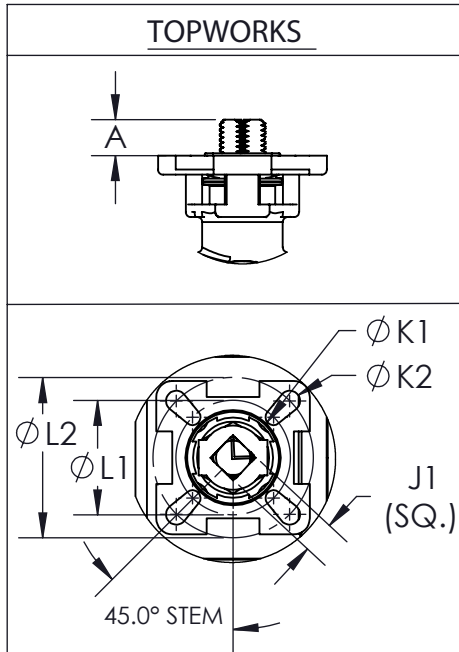

DRAWN BY E.P.	DATE 05/05/2017
CHECKED BY E.G.	DATE 03/23/2018
APPROVED BY J.S.	DATE 03/23/2018

THE INFORMATION CONTAINED IN THIS DRAWING IS THE SOLE PROPERTY OF SVF FLOW CONTROLS, INC. ANY REPRODUCTION IN PART OR IN WHOLE WITHOUT THE WRITTEN CONSENT OF SVF FLOW CONTROLS, INC. IS PROHIBITED.

PROJECTION THIRD ANGLE:



DESCRIPTION:
1/2" - 2" MZ9B 3-WAY DIRECT MOUNT BALL VALVE, L-PORT

UNITS: INCH (MILLIMETERS) DATE: 03/23/2018 REV: C

*AT FULL DIFFERENTIAL PRESSURE FOR CLEAN FLUIDS WITH PTFE SEATS

SIZE	A	øD	E1	E2	E3	F	G1	G2	J1 (SQ.)	øK1	øK2	øL1	øL2	NPT THREAD	ISO 5211	WEIGHT (lbs)	Cv	TORQUE* (in-lbf)
1/2"	0.35 (9)	0.63 (16)	3.39 (86)	2.83 (72)	1.73 (44)	4.84 (123)	3.00 (76)	1.73 (44)	0.35 (9)	0.24 (6)	0.24 (6)	1.42 (36)	1.65 (42)	1/2"-14NPT	F03-F04	3	14	118
3/4"	0.43 (11)	0.79 (20)	3.90 (99)	3.15 (80)	1.89 (48)	6.02 (153)	3.43 (87)	2.13 (54)	0.43 (11)	0.24 (6)	0.28 (7)	1.65 (42)	1.97 (50)	3/4"-14NPT	F04-F05	4	18	180
1"	0.43 (11)	0.98 (25)	4.61 (117)	3.70 (94)	2.24 (57)	6.02 (153)	3.66 (93)	2.32 (59)	0.43 (11)	0.24 (6)	0.28 (7)	1.65 (42)	1.97 (50)	1"-11.5NPT	F04-F05	5	43	217
1-1/2"	0.55 (14)	1.50 (38)	5.83 (148)	4.92 (125)	2.91 (74)	7.20 (183)	4.69 (119)	3.31 (84)	0.55 (14)	0.28 (7)	0.35 (9)	1.97 (50)	2.76 (70)	1-1/2"-11.5NPT	F05-F07	13	90	384
2"	0.55 (14)	1.97 (50)	6.30 (160)	5.12 (130)	3.35 (85)	9.69 (246)	4.92 (125)	3.62 (92)	0.55 (14)	0.28 (7)	0.35 (9)	1.97 (50)	2.76 (70)	2"-11.5NPT	F05-F07	20	160	526

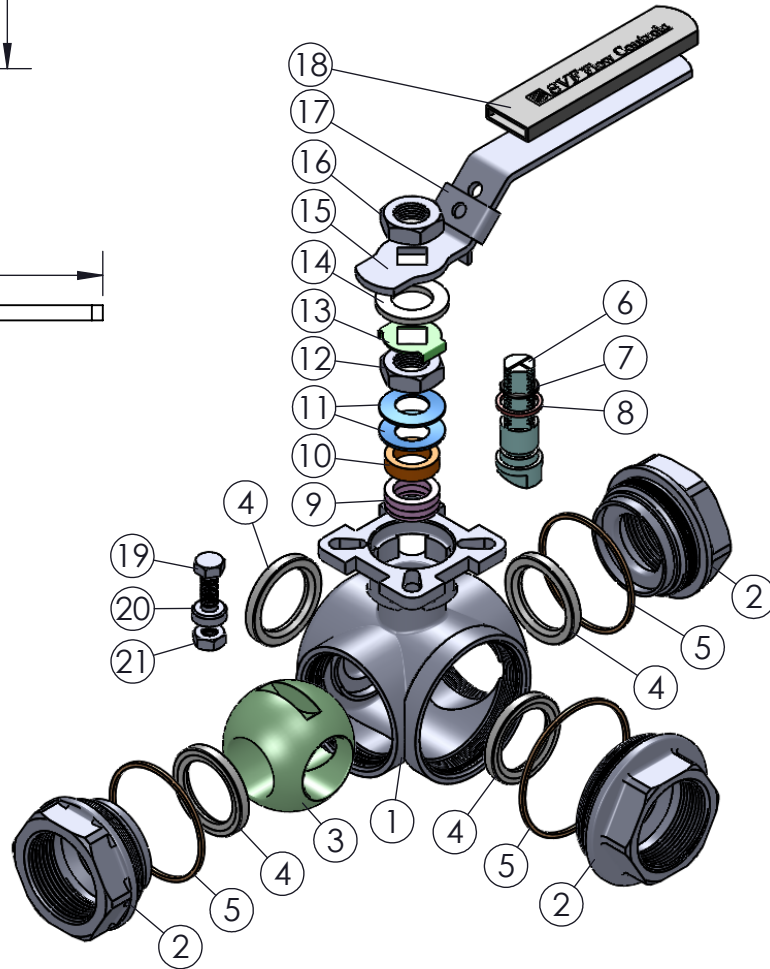
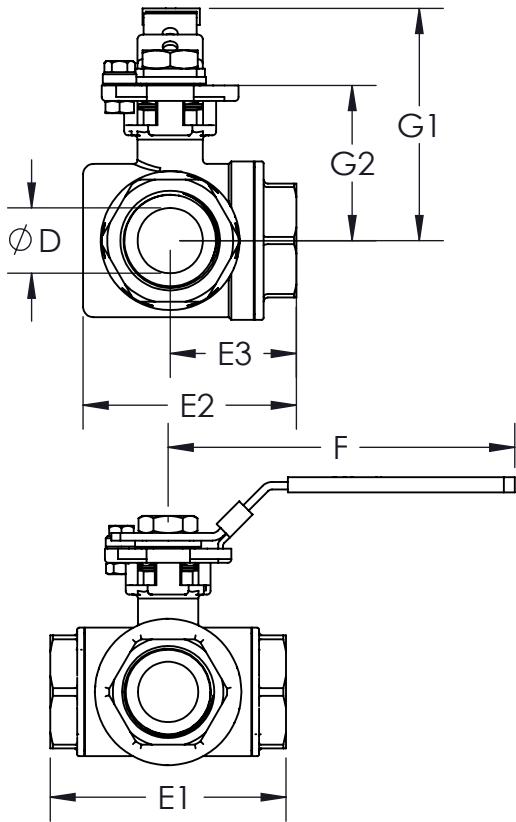

PRODUCT INFORMATION:

1. END CONNECTIONS AVAILABLE IN: SCREWED ENDS (FNPT)
2. BLOW-OUT PROOF STEM/FULL PORT
3. BALL IS VENTED ON THE STEM SLOT AREA
4. LIVE- LOADED STEM SEAL
5. ANTI-STATIC DEVICE
6. COMPLETE VALVE AUTOMATION

APPLICABLE STANDARDS:

1. ASME B16.34: DESIGN
2. API 598: INSPECTION AND TESTING
3. ISO 5211: MOUNTING
4. ISO 228: CLASS A
5. ANSI B1.20.1: NPT
6. CGA G-4.1: CLEANING FOR OXYGEN SERVICE
7. USP CLASS VI: CONFIRMATION OF COMPLIANCE (PTFE MATERIAL)

FLOW PATTERN:

PORT TYPE	1	2	3	4
T	1 ⊕ 2 3	1 ⊕ 2 3	1 ⊕ 2 3	1 ⊕ 2 3

ITEM NO.	DESCRIPTION	MATERIALS	QTY.
1	BODY	A351-CF8M	1
2	END	A351-CF8M	3
3	BALL	A351-CF8M	1
4	SEAT	PTFE	4
5	BODY SEAL	PTFE	3
6	STEM	A276-316	1
7	STEM O-RING	VITON	1
8	STEM THRUST WASHER	TFM4215	1
9	STEM SEAL	PTFE	3
10	SPACER	304 STAINLESS STEEL	1
11	BELLEVILLE WASHER	301 STAINLESS STEEL	2
12	STEM NUT	304 STAINLESS STEEL	1
13	LOCK TAB	304 STAINLESS STEEL	1
14	HANDLE LEVER	304 STAINLESS STEEL	1
15	LEVER HANDLE	304 STAINLESS STEEL	1
16	STEM NUT	304 STAINLESS STEEL	1
17	LOCKING DEVICE	304 STAINLESS STEEL	1
18	HANDLE SLEEVE	PLASTIC	1
19	STOP PIN BOLT	304 STAINLESS STEEL	1
20	STOP PIN	304 STAINLESS STEEL	1
21	STOP PIN NUT	304 STAINLESS STEEL	1

END CONFIGURATION:

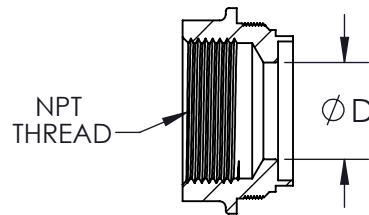

SCREWED END

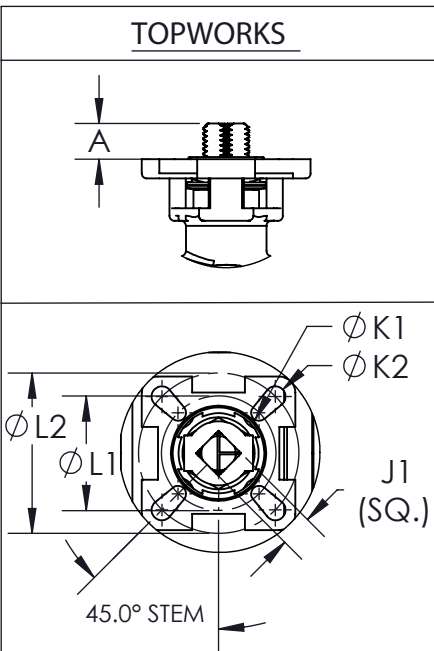

DRAWN BY E.P.	DATE 05/04/2017
CHECKED BY E.G.	DATE 03/23/2018
APPROVED BY J.S.	DATE 03/23/2018

THE INFORMATION CONTAINED IN THIS DRAWING IS THE SOLE PROPERTY OF SVF FLOW CONTROLS, INC. ANY REPRODUCTION IN PART OR IN WHOLE WITHOUT THE WRITTEN CONSENT OF SVF FLOW CONTROLS, INC. IS PROHIBITED.

PROJECTION THIRD ANGLE:

DESCRIPTION:
1/2" - 2" MZ9B 3-WAY DIRECT MOUNT BALL VALVE, T-PORT

UNITS: INCH (MILLIMETERS) DATE: 03/23/2018 REV: C

