

### INSTALLATION, OPERATION & MAINTENANCE MANUAL



#### CAUTION!

Never remove enclosure cover or make/break electrical connections with power connected to the unit.

- ▼ Perform all wiring in accordance with site and local codes and the National Electric Code ANSI-NFPA-70 (US) or the Canadian Electric Code Part I (Canada) for the appropriate area classifications.
- ▼ Ensure that all electrical devices are appropriately rated for the area where they will be operating:  
**NEXUS-LP** = NEMA 4, Weather-proof; **NEXUS-LPX** = Hazardous Area, ATEX.
- ▼ Confirm that supply power to switches is within rated specifications listed on the unit identification label.
- ▼ Protect the unit from exposure to aggressive substances or atmospheres to ensure that the hazardous area rating is not compromised.



#### Air Connections:

When connecting the spool valve to an actuator, it is important to know what position (OPEN/CLOSED) you want the valve to be in, with the solenoid in the de-energized state.

#### 5/2 Aluminum spool valve (Figure 1.1):

- Solenoid De-energized – air flows from Inlet Port 1 to Outlet Port 2 and exhausts from Port 4 to Port 5
- Solenoid Energized – air flows from Inlet Port 1 to Outlet Port 4 and exhausts from Port 2 to Port 3

DOUBLE ACTING ACTUATOR				
Solenoid De-energized State	Air Supply Failure	Spool Valve Port		Actuator Port
Valve Open (Actuator CCW)	Fails Last Position	2	to	A
		4	to	B
Valve Closed (Actuator CW)	Fails Last Position	2	to	B
		4	to	A

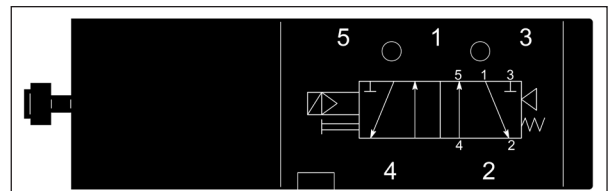
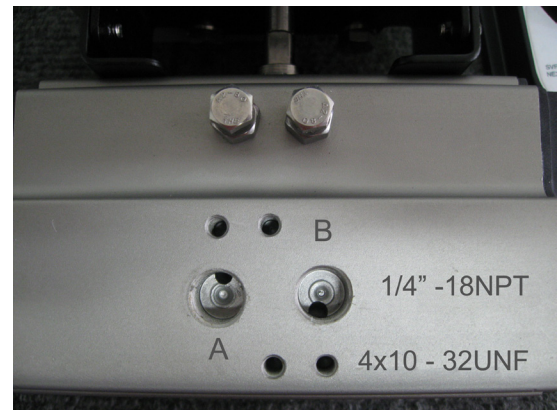

Figure 1.1 - Spool Valve

SPRING RETURN ACTUATOR*				
Solenoid De-energized State	Air Supply Failure	Spool Valve Port		Actuator Port
Valve Open** (Actuator CCW)	OPEN	2-Plugged	to	B-Exhaust
		4	to	A
Valve Closed (Actuator CW)	CLOSED	2-Plugged	to	B-Exhaust
		4	to	A



\*Note: The "fail" position (Open or Closed) is dictated by the arrangement of the Spring Return Actuator. On either (or both) electrical supply or air supply failure, the actuator springs will drive the process valve to the predetermined position. \*\*Note: Reverse Rotating Actuator required.

### INSTALLATION, OPERATION & MAINTENANCE MANUAL



#### INSTALLATION

(For Namur Actuators):

The *NEXUS-LP/LPX* mounting hardware is of a three-piece design. The bottom mounting brackets are two separate identical pieces; the top mounting bracket is one-piece (Figures 2.1 & 2.2).

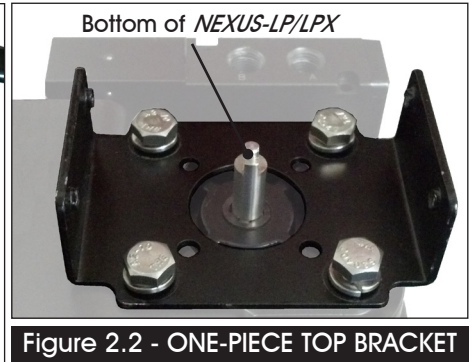

1. Remove the indicator cap from the actuator.
2. Install the two bottom brackets (Figure 2.1) onto the actuator top mount interface (NAMUR) with the supplied 8mm fasteners and washers. Keep the bolts slightly loose (until instructed in Step #6 below).
3. Install the top bracket onto the bottom of the *NEXUS-LP/LPX* with the supplied 14mm fasteners and washers (Figure 2.2).

4. Place the *NEXUS-LP/LPX* onto the actuator ensuring the Spool Valve is facing the side of the actuator where the NPT air inlet manifold is located (Figure 2.3).  
Make sure the *NEXUS-LP/LPX* shaft and actuator shaft are engaged as shown in Figure 2.4.

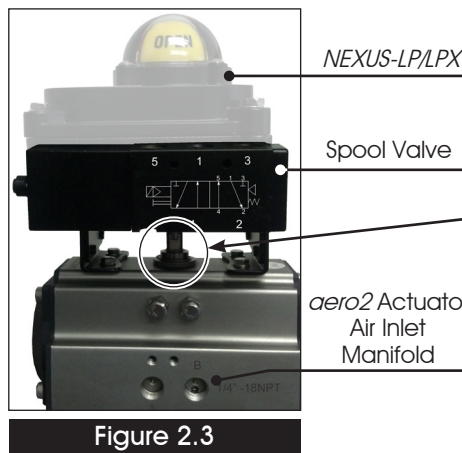

Figure 2.3

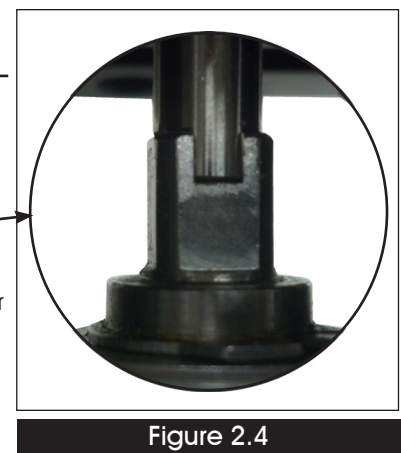

Figure 2.4

5. Fasten the two bottom brackets to the top bracket using the supplied phillips head machine screws and washers (Figure 2.5). Tighten securely.

6. Once the bottom brackets are secured to the top bracket, tighten the (4) 8mm hex head bolts that secure the bottom brackets to the top of the Actuator (Figure 2.6).

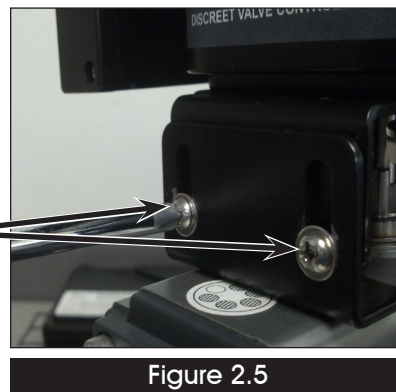

Figure 2.5

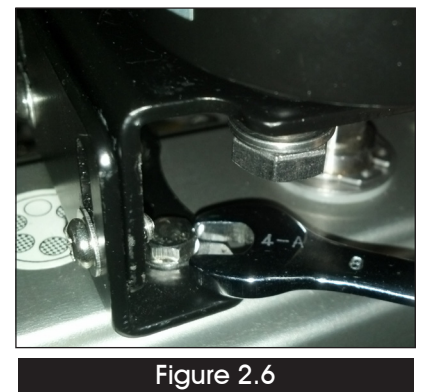

Figure 2.6

## INSTALLATION, OPERATION & MAINTENANCE MANUAL



### FIELD WIRING:

See Page 1 of this document for important cautions/warnings pertaining to the wiring of NEXUS-LP/LPX units.

Required Tools: slotted screw drivers for terminal strip screws, cover screws\* and grounding screw; wire strippers as required for field wires. \*The NEXUS-LPX cover screws require a 5mm allen wrench.

- ▼ Wire the NEXUS-LP/LPX strictly according to the wiring diagram on the inside of the enclosure cover.
- ▼ Confirm that the ground wire is secure under the green grounding screw in the enclosure.
- ▼ Seal all unused conduit entries as required for the area/installation rating.
- ▼ Ensure that only suitably certified cable glands are used.
- ▼ Ensure that the temperature rating of all field wiring meets the service temperature range of the application.



### NEXUS-LP Standard Wiring Diagram (# WDNX2PM2C)

Part # NEXUSLP(\*)M2B(\*\*)

See Page 7 for breakdown of (\*) and (\*\*) in Part Numbers

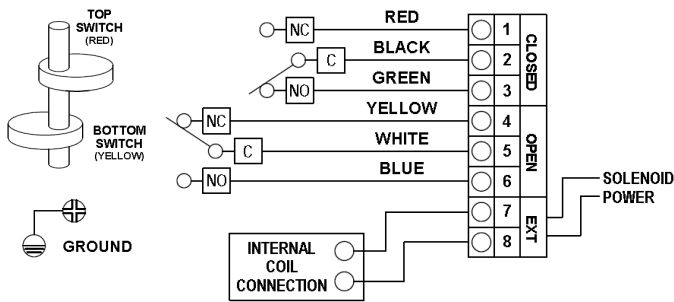

See page 5 for Wiring Diagrams for Optional Switches & Sensors for the NEXUS-LP

### NEXUS-LPX Standard Wiring Diagram (# WDNX2PM2D)

Part # NEXUSLPX(\*)M2B(\*\*)

See Page 7 for breakdown of (\*) and (\*\*) in Part Numbers

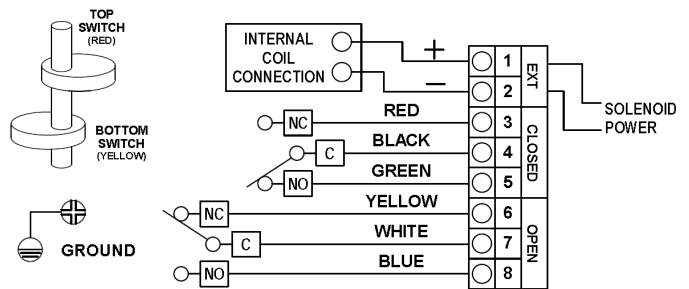

See page 6 for Wiring Diagrams for Optional Switches & Sensors for the NEXUS-LPX

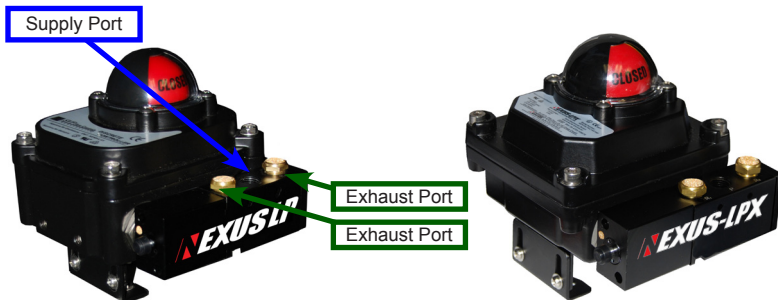

NEXUS-LP = NEMA 4, Weather-proof  
(2 x 1/2" conduit entries)

NEXUS-LPX = Hazardous Area, ATEX  
(1 x 3/4" conduit entry)

Wiring Diagram located inside top cover.



NEXUS-LP



NEXUS-LPX

## INSTALLATION, OPERATION &amp; MAINTENANCE MANUAL

**Cam adjustment for mechanical switches:**

1. Remove housing cover by loosening the screws holding the housing and cover together.
2. Move the valve or valve actuator assembly to the position where the switch(es) will be required to operate.
3. Note the direction of the shaft rotation.
4. Determine which switch is to be adjusted and lift or depress the corresponding cam as required. Rotate the cam in the direction of shaft rotation until the cam engages the switch and closes the normally open contact.
5. Repeat Steps 2-4 until all of the switches are adjusted.
6. Place cover on housing and tighten the screws. To ensure that the shaft alignment is correct, lightly tighten all of the screws until they contact the cover. Tighten them snugly in the standard diagonal pattern.

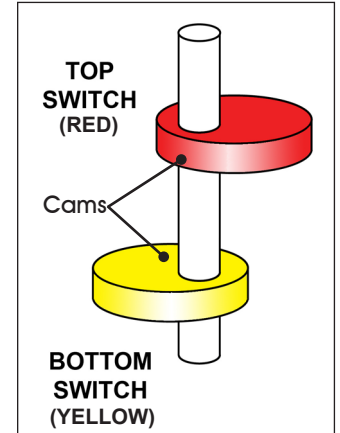
**Cam adjustment for proximity sensors:**

**NOTE:** To properly set sensors, a continuity tester will be required.

1. Remove housing cover by loosening the screws holding the housing and cover together.
2. Move the valve or valve actuator assembly to the position where the switch(es) will be required to operate.
3. Note the direction of the shaft rotation.
4. Determine which switch is to be set and lift or depress the corresponding cam as required. Using the target area as a guide, rotate the cam in the direction of shaft rotation until the pickup on the cam and the target area on the switch are aligned with each other.

**IMPORTANT - To be sure the sensor is now actuated you must use the continuity tester on the adjusted switch.**

5. Repeat Steps 2-4 until all of the switches are adjusted.
6. Place cover on housing and tighten the screws. To ensure that the shaft alignment is correct, lightly tighten all of the screws until they contact the cover. Tighten them snugly in the standard diagonal pattern.

**Cam adjustment for magnetic sensors: NOTE: To properly set sensors, a continuity tester will be required.**

1. Move the valve or valve actuator assembly to the position where the switch(es) will be required to operate.
2. Note the direction of the shaft rotation.
3. Determine which switch is to be set and lift or depress the corresponding cam as required. Using the arrow as a guide, rotate the cam in the direction of shaft rotation until the circle on the cam and the target area on the switch are aligned with each other.

**IMPORTANT - To be sure the sensor is now actuated you must use the continuity tester on the adjusted switch.**

4. Repeat Steps 1-3 until all of the switches are adjusted.
5. Place cover on housing and tighten the screws. To ensure that the shaft alignment is correct, lightly tighten all of the screws until they contact the cover. Tighten them snugly in the standard diagonal pattern.

## NEXUS-LP WIRING DIAGRAMS FOR OPTIONAL SWITCHES & SENSORS

Wiring Diagram# WDNX2Q30S

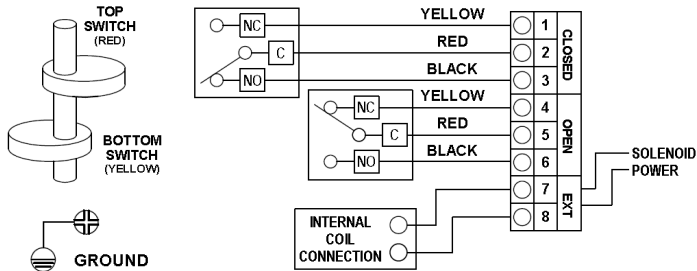

Part # NEXUSLP(\*)Q30(\*\*) = Proximity Sensors NC (3-Wire) Magnetic Sensors

Wiring Diagram# WDNX2M50S

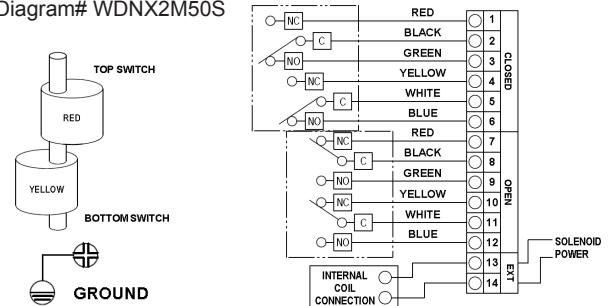

Part # NEXUSLP(\*)M50(\*\*) = Mechanical Switches 2 DPDT

Wiring Diagram# WDNX2P20S

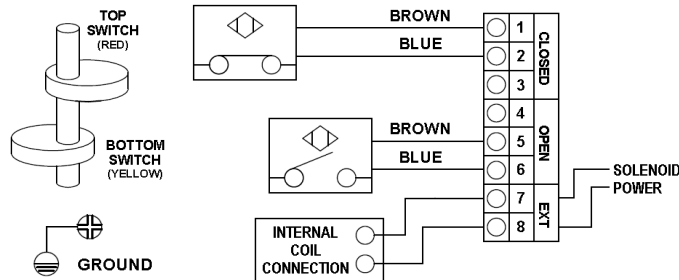

Part # NEXUSLP(\*)P20(\*\*) = Proximity Sensors NO (2-Wire) Inductive Sensors

Wiring Diagram# WDNX2P3AS

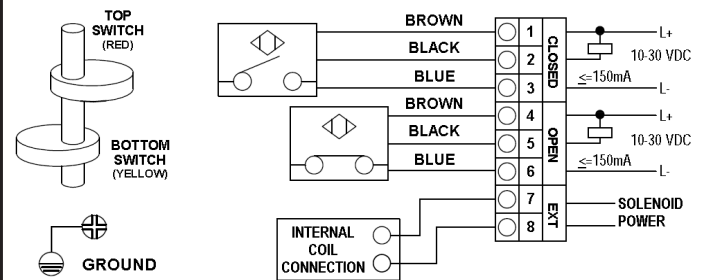

Part # NEXUSLP(\*)P3A(\*\*) = Proximity Sensors NPN NC (3-Wire) Inductive Sensors

Wiring Diagram# WDNX2PP0S

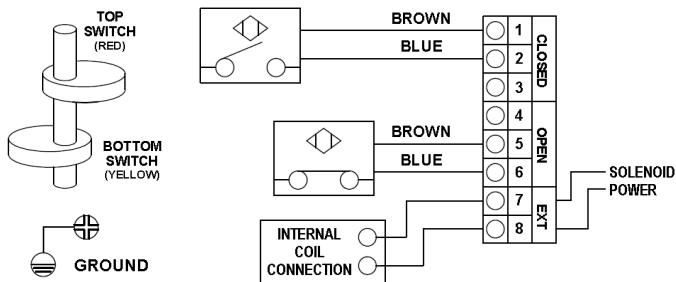

Part # NEXUSLP(\*)PP0(\*\*) = Proximity Sensors NC (2-Wire) (P & F) Inductive Sensors

Wiring Diagram# WDNX2P3BS

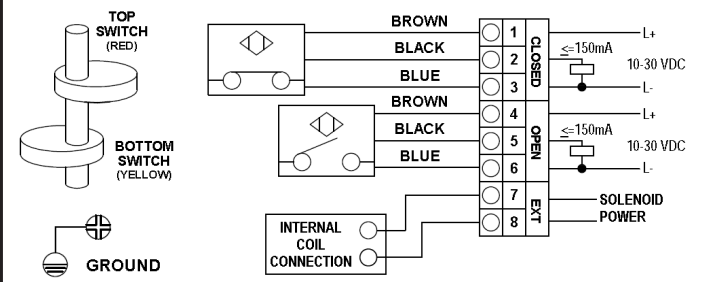

Part # NEXUSLP(\*)P3B(\*\*) = Proximity Sensors PNP NO (3-Wire) Inductive Sensors

Wiring Diagram# WDNX2P30S

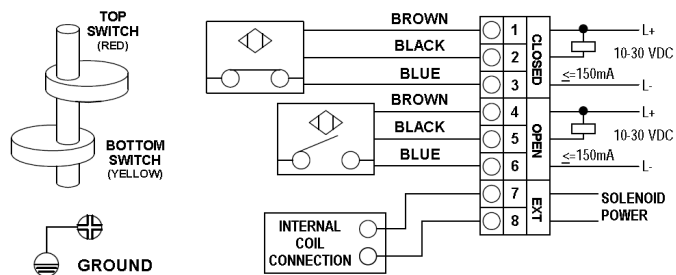

Part # NEXUSLP(\*)P30(\*\*) = Proximity Sensors NPN NO (3-Wire) Inductive Sensors

Wiring Diagram# WDNX2P3CS

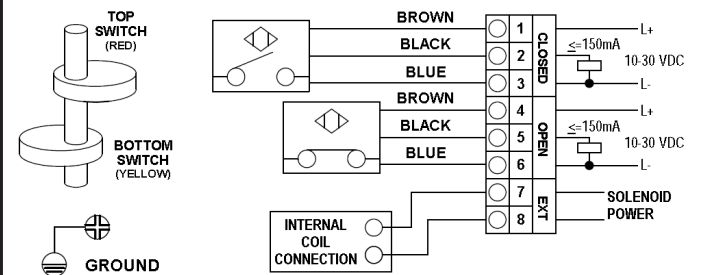

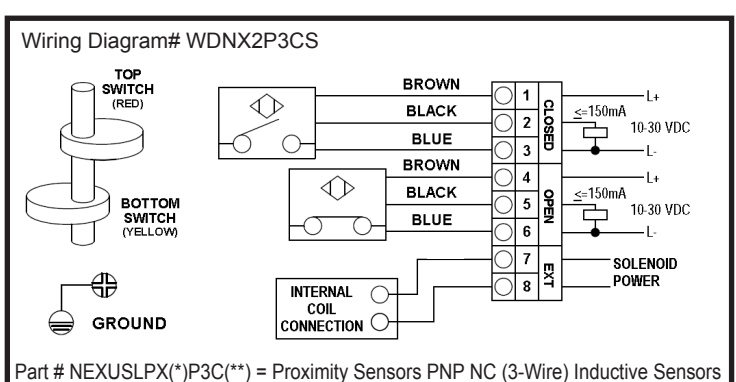
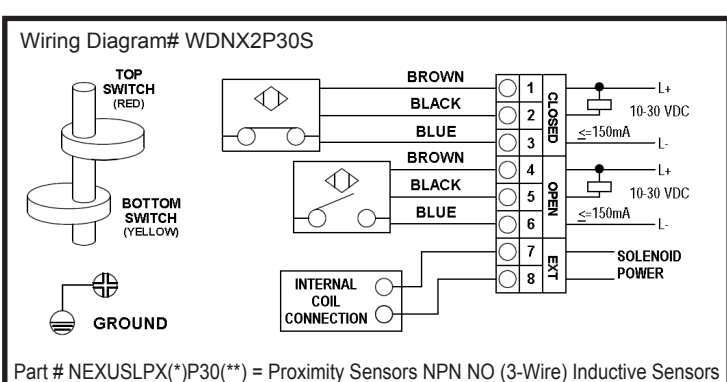
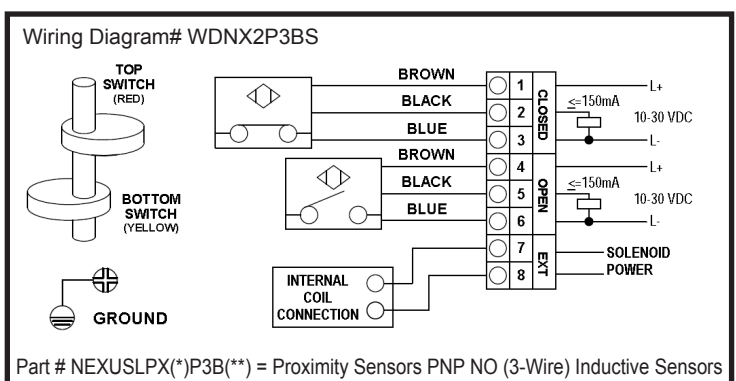
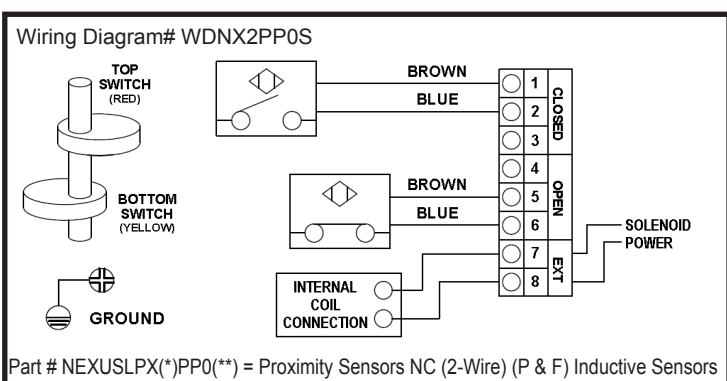
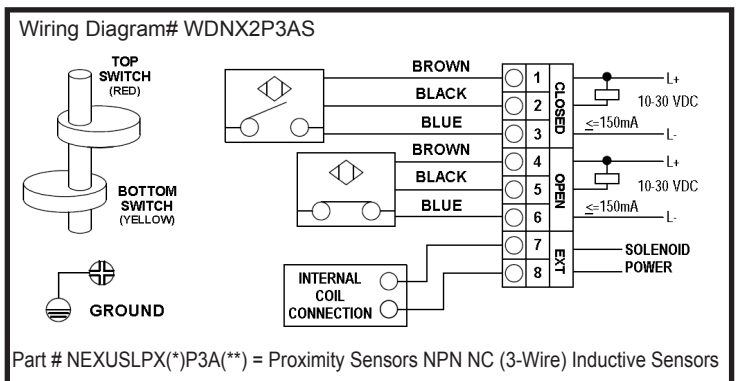
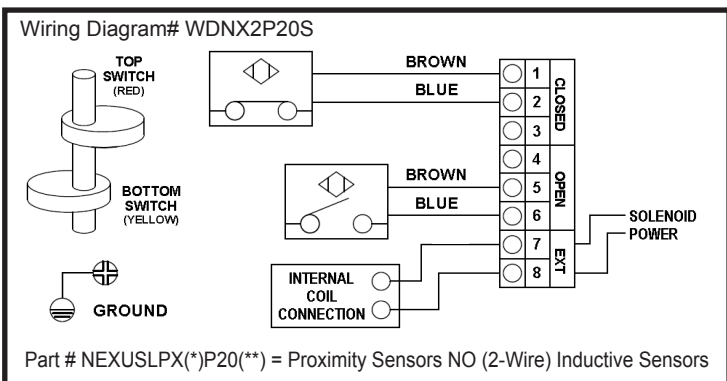
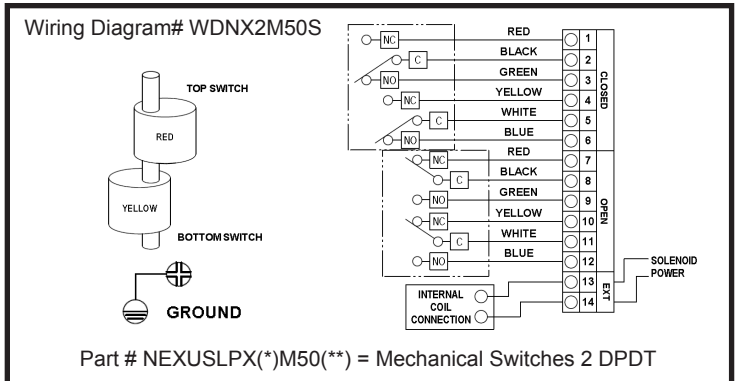
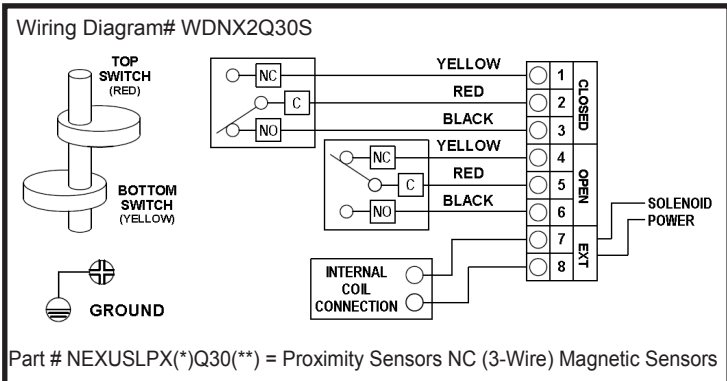

Part # NEXUSLP(\*)P3C(\*\*) = Proximity Sensors PNP NC (3-Wire) Inductive Sensors

### NEXUS-LPX WIRING DIAGRAMS FOR OPTIONAL SWITCHES & SENSORS



### NEXUS-LP AND NEXUS-LPX PART NUMBERING SYSTEM

The Part Number for the NEXUS-LP and NEXUS-LPX includes certain characters that will differ based on the Pilot Coil Voltage, the Switches and Sensors and the Position Indicator Cap.  
Refer to the table below to determine the options that are installed on your particular Limit Switch.

SERIES	PILOT COIL VOLTAGE	SWITCHES/SENSORS	POSITION INDICATOR
<b>NEXUSLP=</b> TWO POSITION DISCRETE VALVE CONTROLLER NEMA 4, 4X IP67  <b>NEXUSLPX=</b> TWO POSITION DISCRETE VALVE CONTROLLER ATEX	4 = 110 VAC (< 2.8VA) (Standard)  2 = C2 Coil 24VDC (< 1 W) 5 = 220VAC (< 2.8VA)  For Intrinsically Safe 3 = C3 Coil 24VDC (<1W)	<b>Mechanical Switches</b> M2B= (Standard) 2 SPDT 15A 125-250VAC, 3A/24VDC  M50= 2 DPDT 15A 125-250VAC, 3A/24VDC  <u>Optional Switches:</u> <u>Proximity Sensors</u>  Q30 = Magnetic Reed Switch 2 SPDT 5-240VAC/VDC, 300mA  P30 = Inductive NPN-NO 3 wire 10-30 VDC, 150mA  P3A = Inductive NPN-NC 3 wire 10-30 VDC, 150mA  P3B = Inductive PNP-NO 3 wire 10-30 VDC, 150mA  P3C = Inductive PNP-NC 3 wire 10-30 VDC, 150mA  PPO = (P & F) Inductive, NC 2 wire 8VDC, 1mA  P20 = Inductive, NO 2 wire 10-30VDC, 150mA	Leave Blank for Standard 90 degree Position Indicator Yellow Open, Red Closed    L = High Visibility Three Way "L" Yellow Base, Red Flow Bar    T = High Visibility Three Way "T" Yellow Base, Red Flow Bar  

**Part Number Example 1: (NEXUSLP4M2B)**

*NEXUS-LP two-position discrete valve controller, 110VAC (Standard), M2B Mechanical Switches (Standard), 90 Degree Open/Closed Position Indicator.*

**Part Number Example 2: (NEXUSLPX3Q30T)**

*NEXUS-LPX two-position discrete valve controller for Hazardous Locations, C3 Pilot Coil Voltage for Intrinsically Safe, Q30 Magnetic Reed Switch, High Visibility Three Way "T" Position Indicator.*