

\*AT FULL DIFFERENTIAL PRESSURE FOR CLEAN FLUIDS

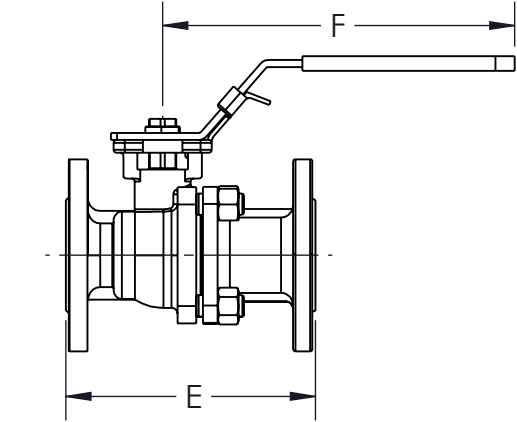

**TOPWORKS:**

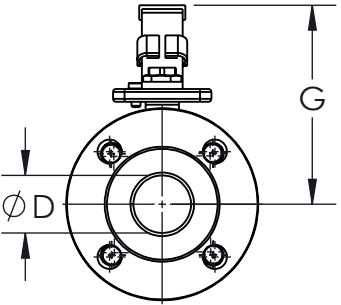
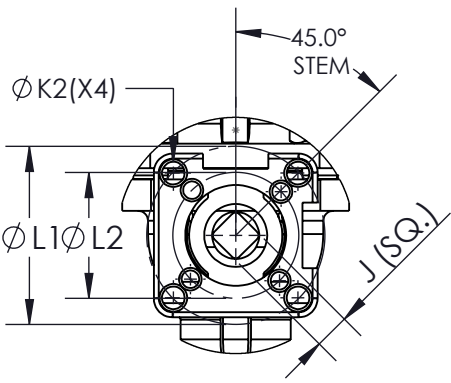
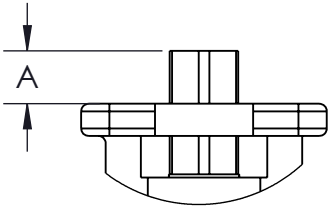

SIZE	A		D		D		F		G		E		F		G	
1/2"	0.31(8.0)	0.59(15.0)	4.25(108.0)	4.72(120.0)	3.34(85.0)	0.35(9.0)	0.23(6.0)	0.23(6.0)	1.65(42.0)	1.41(36.0)	ISO 5211	WEIGHT (lb)	Cv	TORQUE* (in-lbf)		
3/4"	0.31(8.0)	0.78(20.0)	4.60(117.0)	4.72(120.0)	3.42(87.0)	0.35(9.0)	0.23(6.0)	0.23(6.0)	1.65(42.0)	1.41(36.0)	F03-F04	3.74	38	57		
1"	0.39(10.0)	0.98(25.0)	5.00(127.0)	5.70(145.0)	3.66(93.0)	0.43(11.0)	0.23(6.0)	0.27(7.0)	1.96(50.0)	1.65(42.0)	F03-F04	4.62	69	88		
1-1/2"	0.55(14.0)	1.49(38.0)	6.49(165.0)	7.48(190.0)	4.84(123.0)	0.55(14.0)	0.27(7.0)	0.35(9.0)	2.75(70.0)	1.96(50.0)	F04-F05	6.17	113	99		
2"	0.55(14.0)	1.96(50.0)	7.00(178.0)	7.48(190.0)	5.19(132.0)	0.55(14.0)	0.27(7.0)	0.35(9.0)	2.75(70.0)	1.96(50.0)	F05-F07	13.2	273	203		
2-1/2"	0.66(17.0)	2.55(65.0)	7.48(190.0)	17.7(450.0)	6.22(158.0)	0.66(17.0)	0.35(9.0)	0.43(11.0)	4.01(102.0)	2.75(70.0)	F05-F07	17.63	485	269		
3"	0.66(17.0)	3.07(78.0)	7.99(203.0)	17.7(450.0)	6.49(165.0)	0.66(17.0)	0.35(9.0)	0.43(11.0)	4.01(102.0)	2.75(70.0)	F07-F10	32.1	816	424		
4"	0.74(19.0)	3.93(100.0)	9.01(229.0)	17.7(450.0)	7.48(190.0)	0.74(19.0)	0.35(9.0)	0.43(11.0)	4.01(102.0)	2.75(70.0)	F07-F10	40.5	1185	584		
6"	1.06(27.0)	5.90(150.0)	15.5(394.0)	31.4(800.0)	11.0(280.0)	1.06(27.0)	N/A	0.51(13.0)	4.92(125.0)	N/A	F12	N/A	3900	1416		

**Product Information:**

- LIVE-LOADED STEM PACKING
- STANDARD LOCKING HANDLE
- BALL IS VENTED ON THE STEM SLOT AREA
- ANTI-STATIC DEVICE
- COMPLETE VALVE AUTOMATION
- ALL STAINLESS STEEL PASSIVATED

**OPTIONS:**

- ISO STEM EXTENSION
- STEAM JACKET

**APPLICABLE STANDARDS:**

- NACE MR0175
- ASME B16.34: DESIGN AND WALL THICKNESS
- ASME B16.10: FACE TO FACE
- ASME B16.5: END FLANGE
- API 598: INSPECTION AND TESTING
- ISO 5211: MOUNTING
- USP CLASS VI: CONFIRMATION OF COMPLIANCE (TFM1600/PTFE MATERIAL)
- FUGITIVE EMISSIONS: API 641

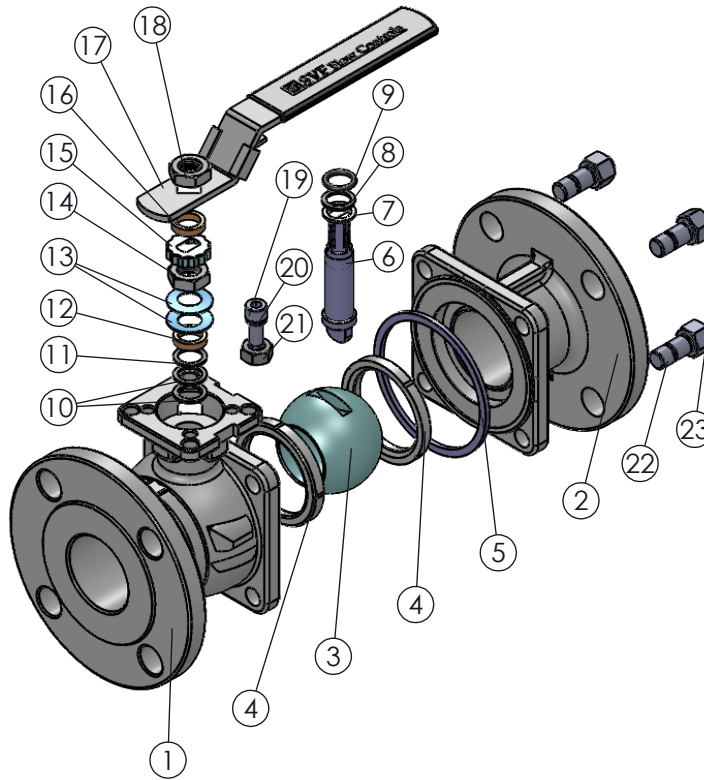

**SIZES 2-1/2" - 6" WITH PIPE HANDLE:**

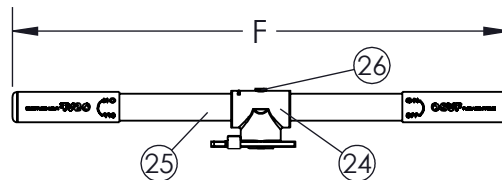

ITEM NO.	Description	MATERIALS	QTY.
1	BODY	A351 CF8M A216-WCB	1
2	END	A351 CF8M A216-WCB	1
3	BALL	A182 F316	1
4	SEAT	TFM1600 SUPRALON	2
5	BODY SEAL	GRAPHITE PTFE	1
6	STEM	A276 316	1
7	THRUST WASHER	GRAFOIL PTFE	1
8	THRUST WASHER	PTFE+25%G.F.	1
9	STEM O-RING	VITON	1
10	STEM SEAL	GRAFOIL PTFE SLADE 330I	1
11	STEM SEAL	PTFE+25%G.F.	1
12	GLAND	A276 304	1
13	BELLEVILLE WASHER	A276 304	2
14	STEM NUT	A276 304	1
15	TAB WASHER	A276 304	1
16	GLAND	A276 304	1
17	HANDLE	A276 304	1
18	HANDLE NUT	A276 304	1
19	STOP PIN	A276 304	1
20	PIN WASHER	A276 304	1
21	PIN NUT	A276 304	1
22	BODY BOLT	A193 B8M	4
23	BODY NUT	A94 8M	4
24	ADAPTER	A351 CF8	1
25	PIPE HANDLE	A276 304	1
26	ADAPTER SET SCREW	A354 CF8	1

DRAWN BY B.B.	DATE 10/19/2022
CHECKED BY C.L.	DATE 10/19/2022
APPROVED BY J.S.	DATE 10/19/2022

**SVF FLOW CONTROLS**  
 5595 Fresca Drive • La Palma, CA 90623 • 1.800.783.7836  
 www.SVF.net • Sales@SVF.net

DESCRIPTION: 1/2"-6" B41D FLANGED BALL VALVE, FULL PORT, ASEM CLASS 150 RF.  
 (FOR REF ONLY IF NOT APPROVED)

UNITS: Inch (millimeters)	DATE: 12/16/2022	REV: A
---------------------------	------------------	--------