

### INSTALLATION, OPERATION & MAINTENANCE FOR SVF SERIES VB41 BALL VALVES



60° V Ball



30° V Ball

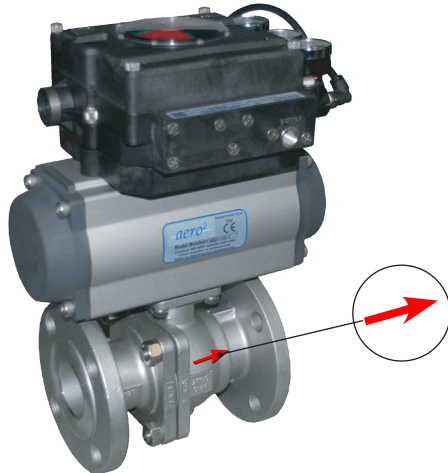

VB41 Automated Package  
(2" Valve shown with *aero*<sup>2</sup> Actuator & SVF Positioner)

#### GENERAL

SVF Ball valves have been designed and engineered to provide long lasting and trouble free service when used in accordance with the instructions and specifications herein.

The following instructions refer only to SVF Series VB41 Control "V" Port Ball Valves.

Keep protective cover in place until moment of installation. Valve performance depends upon preventing of damage to ball surface. Upon removal of cover, make sure that the valve is completely open and free of obstruction.

If requested, valves can be shipped from the factory containing a silicon based lubricant which aids in the assembly of the valve. This may be removed with a solvent if found intolerable.

Certain ferrous valves are phosphate and oil dipped during the course of manufacture, but they are completely non-toxic and the valves are quite safe to use for edible or potable products.

#### STORAGE:

All manual valves are shipped in the fully open position with protective end caps (covers). Keep all protective packaging, flange covers, or end caps attached to the valves during storage. To avoid damage to the seat due to contact with the balls edge, leave the valve in the **fully open or closed position** during storage. It is recommended to keep the valves in a clean and dry environment until ready for use.

#### !!!CAUTION! Safety Precautions!!!

Before removing valve from pipeline NOTE that:

Media flowing through a valve may be corrosive, toxic, flammable, a contaminant or harmful nature. Where there is evidence of harmful fluids having flowed through the valve, the utmost care must be taken. It is suggested that the following minimal safety precautions be taken when handling valves.

1. Always wear eye shields.
2. Always wear gloves and overalls.
3. Wear protective footwear.
4. Wear protective headgear.
5. Ensure that running water is readily accessible.
6. Have a suitable fire extinguisher ready if media is flammable.
7. Be sure that you are aware of the fluid that has been passing through the valve before opening or dismantling any valve. Require MSDS information.

By checking line gauges ensure that no pressure is present at the valve.

Ensure that any media is released by operating valve slowly to half open position. Ideally, the valve should be decontaminated when the ball is in the half open position.

These valves, when installed, have body connectors which form an integral part of the pipeline and the valve cannot be removed from the pipeline without being dismantled.

Valves and accessories must not be used as a sole support of piping or human weight. Safety accessories such as safety relief (overpressure) valves are the responsibility of the system designer.

It is the user/system designer's responsibility to use insulation in high temperature applications. Refer to OSHA documents for more details.

What do you need today?™

HIGH PURITY  
CleanFLOW®

PRO-SPEC  
PROCESS SPECIFIC  
WWW.PRO-SPEC.NET

QUALITY FLOWS  
THROUGH US

Please visit [www.SVF.net](http://www.SVF.net) for the latest updates on this document. All data posted on our website supersede all prior publications • [Document #SVF\_VB41\_IOM • Series VB41 IOM - 03/24/2016]

[www.SVF.net](http://www.SVF.net)

SVF Flow Controls, Inc. • 13560 Larwin Circle • Santa Fe Springs, CA 90670 • Tel: 1.800.783.7836 • FAX: 562.802.3114  
Sales@SVF.net • Visit our website: [www.SVF.net](http://www.SVF.net) • © SVF Flow Controls, Inc. • Specifications subject to change without notice

## INSTALLATION, OPERATION & MAINTENANCE FOR SVF SERIES VB41 BALL VALVES

### INSTALLATION

The valve must be installed for flow or vacuum in one direction (Arrow on side of body denotes direction of flow). Carefully exclude pipe sealants from the valve cavity. When installing, use standard gaskets suitable for the specific service. Tighten flange bolts or studs evenly.

### OPERATION

SVF valves provide excellent modulating control when used under normal conditions and in accordance with SVF's published pressure/temperature chart.

SVF valves have 1/4 turn operation closing in a clockwise direction.

Any media which might solidify, crystallize or polymerize should not be allowed to stand in the ball valve cavities unless regular maintenance is provided. If minimal maintenance is required, SVF offers steam jacketed ball valves.

### TORQUE REQUIREMENTS

Torque ratings are subject to variations depending on the length of time between cycles and the media in the system.

Breakaway torque is that force which must be exerted to cause the ball to begin to open. Operating torque requirements will vary depending on the length of time between cycles, media in the system, line pressure and type of valve seat.

### MAINTENANCE

With self-wiping ball/seats, SVF valves have a long, trouble free life, and maintenance is seldom required. But, when necessary, valves may be refurbished, using a small number of components, none of which require machining.

SVF valves are designed for easy service and assembly in the field. The following checks will help to extend valve life, or reduce plant problems.

SVF Ball Valves utilize live-loaded stem seals featuring Belleville washers (disk springs) that maintain constant pressure on the packing area even under a wide range of pressure and temperature fluctuations. If stem leakage is evident proceed as follows:

#### STEM LEAKAGE\*

Examine the disk springs (Belleville washers) for damage. If in good condition tighten the gland nut until disk springs are firmly compressed, then back nut off 1/16<sup>th</sup> of a turn. If damaged, dismantle the stem down to the gland, fit new disk springs with their outer edges touching, replace and retighten using gland nut. Further maintenance necessitates dismantling of the valve.

#### LEAKAGE AT END CAP JOINT\*

Check for tightness at the End Cap connector. If loose, tighten End Cap. Excessive force will damage the End Cap. Follow the torque values listed in Table A, Page 4. If there is still leakage it will be necessary to dismantle the valve and replace the body seal.

#### IN-LINE LEAKAGE

Check that valve is fully closed. If leakage occurs while the valve is in the closed position, a seat or ball sealant surface may be damaged and it will be necessary to disassemble the valve.

\*NOTE: Stem leakage and leakage at the end cap joint, if not cured by simple means described above, may necessitate dismantling valve. If there is no stem leakage the stem assembly should not be touched.

### INSTALLATION, OPERATION & MAINTENANCE FOR SVF SERIES VB41 BALL VALVES

#### REBUILDING

Before rebuilding, check that all the correct components are available and that they are fit for reassembling. When rebuilding, cleanliness is essential to allow long valve life and provide cost effective maintenance. CAUTION: NO BODY OR STEM SEALS ARE REUSABLE. Care must be taken to avoid scratching the seats and seal during installation.

**Note:** Caution must be taken with valves that have been in hazardous media. They must be decontaminated before disassembly by relieving the line pressure and flushing the line with the valve in the partially open position. Protective clothing and face shields, gloves, etc. MUST BE USED for this operation. Remove any accessories attached to the valve before attempting disassembly of valve.

#### A DISASSEMBLY OF VALVE (Removed from line)

- 1.) With the valve in the open position, undo Body Bolt Nuts (#14) to separate valve Body (#1) and End Cap (#2).
- 2.) Once the Body (#1) and End Cap (#2) have been separated, remove the Body Seal (#6).
- 3.) Make sure the Ball is in the closed position, thus the Ball (#3) can be taken out easily from the Body (#1).
- 4.) Once the Ball (#3) is removed from the Body (#1), take out the Seats (#5).

#### B REMOVING STEM ASSEMBLY - 2"

- 1.) If manually operated, remove the Handle (#14) by removing the Handle Nut (#15).
- 2.) Remove the Handle Glands (#13), Tab Lock (#12), Stem Nut (#11), Belleville Washers (#10), Gland (#9), Bushing (#8) and Stem Seals (#7).

#### B-1 REMOVING STEM ASSEMBLY - 3" to 6"

- 1.) Loosen Set Screw (#26) on Handle Adapter (#25) to remove the Pipe Handle (#27) and Triangular Stopper (#22).

- 2.) Remove Tab Lock (#12), Stem Nut (#11), Belleville Washers (#10), Gland (#9), Bushing (#8), and Stem Seal (#7).
- 3.) Push the Stem (#4) down into the body cavity to remove, once removed take off the O-Ring (#19) and Thrust Washer (#20).

#### C INSPECTION

- 1.) The ball and the surfaces of the seats should be free of pit marks and scratches. Light marring from the action of the ball against the seats is normal and will not affect the operation of the valve.
- 2.) The stem, thrust bearing, steam seal and surrounding body surfaces should be free of pit marks and scratches.

#### D REASSEMBLY

- 1.) Apply an adequate amount of lubricant, compatible with the media being handled, around the Ball (#3), Seats (#5), Body Seal (#6), Stem (#4), and Thrust Washer (#20).
- 2.) For stem reassembly, disassembly procedure should be followed in reverse order.
- 3.) When stem assembly is complete, tighten Stem Nut (#11) according to the values in Table A.
- 4.) Insert a Seat (#5) into the Body (#1) followed by the Ball (#3) making sure the Stem (#4) in the close position so that stem slot engages with the tang at the base of the stem. Make sure the ball's "V" Port is in the downstream direction, when open, as indicated by the directional arrow (→) on the valve body.
- 5.) Make sure Body Seal (#6) rests squarely on center seal surface of the body.
- 6.) Place the second Seat onto the End Cap (#2). Make sure the seats rest firmly on the back surface of each recess.
- 7.) Insert and tighten Body Bolts(#13) and Body Nuts (#14) diagonally, in accordance to the cross pattern procedure.
- 8.) In the final assembly step ensure that body bolts are tightened accordingly to the torques values in Table A.

**See Page 5 for additional information on installing the valve handle.**



### INSTALLATION, OPERATION & MAINTENANCE FOR SVF SERIES VB41 BALL VALVES

#### TORQUE SPECS

Certain precautions need to be followed when tightening bolts down to their corresponding torques to help prevent bolt galling.

There are two passes each bolt has to undergo during the process, first pass and the final pass. Once every bolt has met the first pass requirement, the final pass can be initiated. When tightening down bolts it is necessary to follow the corresponding bolt pattern shown below.

#### REPAIR KITS

Repair Kits are available from SVF Flow Controls, Inc. Table B below shows what the kits consist of. When ordering a Repair Kit, please be sure to specify the type, size and seating material of the valve.

When repairing a valve use only SVF Flow Controls, Inc. authorized spare parts including; bolts and nuts, etc. In addition to maintenance kits, spare parts are available from SVF Flow Controls, Inc. They are: balls and stem. If additional parts are required (body and ends) it is normally recommended that the complete valve be replaced.

Components from a different valve series should not be used with the repair of any other valve. If the valve is altered in any way, no liability can be accepted by SVF Flow Controls, Inc.

**TABLE A: TORQUE REQUIREMENTS (in-lbs)**

Valve Size	Bolt Pattern	Body Bolts (Carbon Steel or Stainless Steel)		Stem Nuts
		First Pass	Final Pass	
2"	4	240	400	140 ~ 160
3"	6	348	580	180 ~ 200
4"	8	348	580	250 ~ 270
6"	10	480	800	300 ~ 350

**TABLE B: GENERAL REPAIR KIT**

Part	Quantity
Thrust Washer	1
Stem Seals	3
Belleville Washers	2
Seats	2
Body Seal	1
O-Ring	1

### VB41 BOLT PATTERNS - BOLT TIGHTENING SEQUENCE

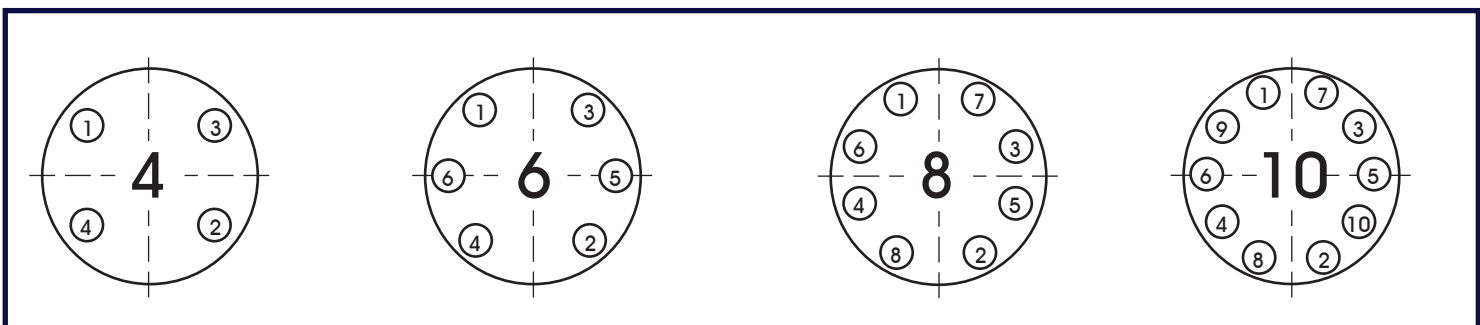

### MATERIALS OF CONSTRUCTION FOR SVF SERIES VB41 BALL VALVES

Item #	Part Name	Materials		Recommended Spare	Wetted
1	Body	A351-CF8M	A216-WCB	-	X
2	End Cap	A351-CF8M	A216-WCB	-	X
3	Ball	A351-CF8M		-	X
4	Stem	A193-B8		-	X
5	Seat	TFM1600™	SupraLon™	X	X
6	Body Seal	316 + GRAFOIL®	PTFE	X	X
7	Stem Seal	GRAFOIL®	PTFE	X	-
8	Bushing	SUS304		X	-
9	Gland	SUS316		-	-
10	Belleville Washer	SUS301		X	-
11	Stem Nut	A194-8		-	-
12	Tab Lock	SUS304		-	-
13	Handle Gland	SUS304		-	-
14	Handle (2")	SUS304		-	-
15	Handle Nut	A194-8		-	-
16	Body Bolt	A193-B8		-	-
17	Body Nut	A194-8		-	-
18	Locking Device (2")	SUS304		-	-
19	O-Ring	Viton®		X	-
20	Thrust Washer	SupraLon™		X	X
21	Anti-Static Device	SUS316		-	-
22	Triangular Stopper (3"~6")	SUS304		-	-
23	Stop Bolt	A193-B8		-	-
24	Stop Washer	A194-8		-	-
25	Pipe Handle Adapter (3"~6")	A351-CF8		-	-
26	Adapter Set Screw (3"~6")	A193-B8		-	-
27	Pipe Handle (3"~6")	SUS304		-	-
28	Pipe Handle Set Screw (3"~6")	A193-B8		-	-

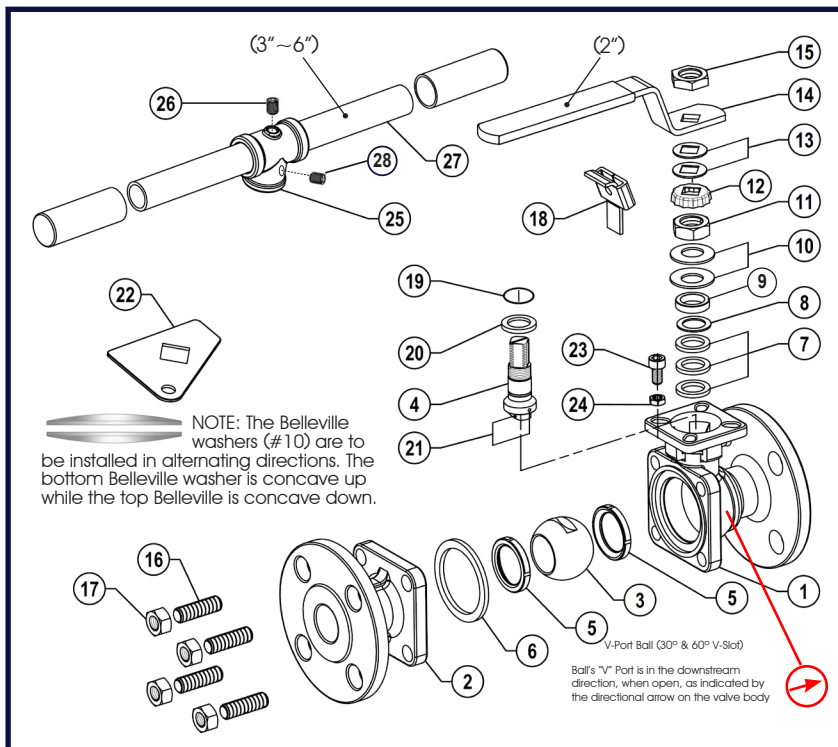

### VALVE HANDLE INSTALLATION

**NOTE:** After valve assembly is completed, install the proper valve handle parallel to the groove on the top of the stem as shown.

**For 2" Valves:**

Slide the Handle (#19) over the top of the Stem (#4) and tighten the Handle Nut (#18)

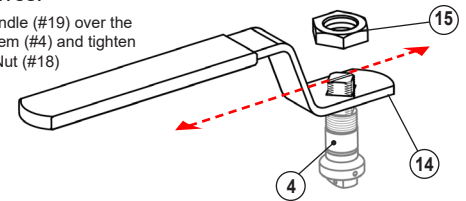

**For 3"~6" Valves:**

Slide the Pipe Handle (#20) through the Pipe Handle Adapter (#21) and tighten the Adapter Set Screw (#22)

Slide the Pipe Handle (#20) over the top of the Stem (#4) and Tighten Pipe Handle Set Screw (#23)

